

This manual should be considered a permanent part of the vehicle and should remain with the vehicle when it is resold.

This publication includes the latest production information available before printing. Honda Motor Co., Ltd. reserves the right to make changes at any time without notice and without incurring any obligation.

No part of this publication may be reproduced without written permission.

The vehicle pictured in this owner's manual may not match your actual vehicle.

Welcome

Congratulations on your purchase of a new Honda vehicle. Your selection of a Honda makes you part of a worldwide family of satisfied customers who appreciate Honda's reputation for building quality into every product.

To ensure your safety and riding pleasure:

- Read this owner's manual carefully.
- Follow all recommendations and procedures contained in this manual.
- Pay close attention to safety messages contained in this manual and on the vehicle.

- The following codes in this manual indicate each country.
- The illustrations here in are based on the FSH125 ED type.

Country Codes

Code	Country
------	---------

FSH125

ED	European direct sales
E	UK

*The specifications may vary with each locale.

A Few Words About Safety

Your safety, and the safety of others, is very important. Operating this vehicle safely is an important responsibility.

To help you make informed decisions about safety, we have provided operating procedures and other information on safety labels and in this manual. This information alerts you to potential hazards that could hurt you or others.

Of course, it is not practical or possible to warn you about all hazards associated with operating or maintaining a vehicle. You must use your own good judgement.

You will find important safety information in a variety of forms, including:

- Safety labels on the vehicle
- Safety Messages preceded by a safety alert symbol  and one of three signal words: DANGER, WARNING, or CAUTION.

These signal words mean:

DANGER

You **WILL** be **KILLED** or **SERIOUSLY HURT** if you don't follow instructions.

WARNING

You **CAN** be **KILLED** or **SERIOUSLY HURT** if you don't follow instructions.

CAUTION

You **CAN** be **HURT** if you don't follow instructions.

Other important information is provided under the following titles:

NOTICE Information to help you avoid damage to your vehicle, other property, or the environment.

Contents

Vehicle Safety P. 2

Operation Guide P. 18

Maintenance P. 63

Troubleshooting P. 101

Information P. 124

Specifications P. 138

Vehicle Safety

This section contains important information for safe riding of your vehicle.
Please read this section carefully.

Safety Guidelines	P. 3
Image Labels	P. 6
Safety Precautions	P. 10
Riding Precautions	P. 11
Accessories & Modifications	P. 15
Loading	P. 16

Safety Guidelines

Safety Guidelines

Follow these guidelines to enhance your safety:

- Perform all routine and regular inspections specified in this manual.
- Stop the engine and keep sparks and flame away before filling the fuel tank.
- Do not run the engine in enclosed or partly enclosed areas. Carbon monoxide in exhaust gases is toxic and can kill you.

Always Wear a Helmet

It's a proven fact: helmets and protective apparel significantly reduce the number and severity of head and other injuries. So always wear an approved helmet and protective apparel. 📖 P. 10

Before Riding

Make sure that you are physically fit, mentally focused and free of alcohol and drugs. Check that you and your passenger are both wearing an approved helmet and protective apparel.

Instruct your passenger on holding onto the grab rail or your waist, leaning with you in turns, and keeping their feet on the footpegs, even when the vehicle is stopped.

Take Time to Learn & Practice

Even if you have ridden other vehicles, practice riding in a safe area to become familiar with how this vehicle works and handles, and to become accustomed to the vehicle's size and weight.

Ride Defensively

Always pay attention to other vehicles around you, and do not assume that other drivers see you. Be prepared to stop quickly or perform an evasive maneuver.

Make Yourself Easy to See

Make yourself more visible, especially at night, by wearing bright reflective clothing, positioning yourself so other drivers can see you, signaling before turning or changing lanes, and using your horn when necessary.

Safety Guidelines

Ride within Your Limits

Never ride beyond your personal abilities or faster than conditions warrant. Fatigue and inattention can impair your ability to use good judgement and ride safely.

Don't Drink or Use Drugs and Ride

Alcohol or drugs and riding don't mix. Even one alcoholic drink can reduce your ability to respond to changing conditions, and your reaction time gets worse with every additional drink. The same is true for drug use. Don't drink or use and ride, and don't let your friends do it either.

Keep Your Honda in Safe Condition

It's important to keep your vehicle properly maintained and in safe riding condition. Inspect your vehicle before every ride and perform all recommended maintenance. Never exceed load limits (▶ P. 16), and do not modify your vehicle or install accessories that would make your vehicle unsafe (▶ P. 15).

If You are Involved in a Crash

Personal safety is your first priority. If you or anyone else has been injured, take time to assess the severity of the injuries and whether it is safe to continue riding. Call for emergency assistance if needed. Also follow applicable laws and regulations if another person or vehicle is involved in the crash.

If you decide to continue riding, first turn the ignition switch to the **O** (Off) position, and evaluate the condition of your vehicle. Inspect for fluid leaks, check the tightness of critical nuts and bolts, and check the handlebar, control levers, brakes, and wheels. Ride slowly and cautiously.

Your vehicle may have suffered damage that is not immediately apparent. Have your vehicle thoroughly checked at a qualified service facility as soon as possible.

Safety Guidelines

Carbon Monoxide Hazard

Exhaust contains poisonous carbon monoxide, a colourless, odorless gas. Breathing carbon monoxide can cause loss of consciousness and may lead to death.

If you run the engine in confined or even partly enclosed area, the air you breathe could contain a dangerous amount of carbon monoxide.

Never run your vehicle inside a garage or other enclosure.

WARNING

Running the engine of your vehicle while in an enclosed or even partially enclosed area can cause a rapid build-up of toxic carbon monoxide gas.

Breathing this colourless, odorless gas can quickly cause unconsciousness and lead to death.

Only run your vehicle's engine when it is located in a well ventilated area outdoors.

Vehicle Safety

Image Labels

Image Labels

Vehicle Safety

The following pages describe the label meanings. Some labels warn you of potential hazards that could cause serious injury. Others provide important safety information. Read this information carefully and don't remove the labels.

If a label comes off or becomes hard to read, contact your dealer for a replacement.

There is a specific symbol on each label. The meanings of each symbol and label are as follows.



Read instructions contained in Owner's Manual carefully.



Read instructions contained in Shop Manual carefully. In the interest of safety, take the vehicle to be serviced only by your dealer.



DANGER (with RED background)

You **WILL** be **KILLED** or **SERIOUSLY HURT** if you don't follow instructions.

WARNING (with ORANGE background)

You **CAN** be **KILLED** or **SERIOUSLY HURT** if you don't follow instructions.

CAUTION (with YELLOW background)

You **CAN** be **HURT** if you don't follow instructions.

Image Labels



BATTERY LABEL DANGER

- Keep flame and spark away from the battery. Battery produce explosive gas that can cause explosion.
- Wear the eye protection and rubber gloves when handling the battery, or you can get burned or lose your eyesight by the battery electrolyte.
- Do not allow children and other people to touch a battery unless they understand proper handling and hazards of the battery very well.
- Handle the battery electrolyte with extreme care as it contains dilute sulfuric acid. Contact with your skin or eyes can burn you or cause loss of your eyesight.
- Read this manual carefully and understand it before handling the battery. Neglect of the instructions can cause personal injury and damage to the vehicle.
- Do not use a battery with the electrolyte at or below the lower level mark. It can explode causing serious injury.

Continued 7

Image Labels

Vehicle Safety

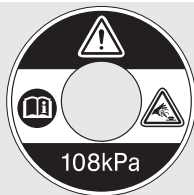

RADIATOR CAP LABEL DANGER

NEVER OPEN WHEN HOT.

Hot coolant will scald you.

Relief pressure valve begins to open at **108 kPa**.

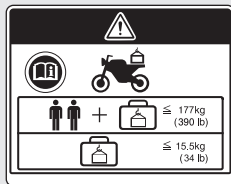

ACCESSORIES AND LOADING WARNING LABEL WARNING

ACCESSORIES AND LOADING

- The safety stability and handling of this vehicle may be affected by the addition of accessories and luggage.
- Read carefully the instructions contained in user's manual and installation guide before installing any accessory.
- The total weight of accessories and luggage added to rider's and passenger's weight should not exceed **177 kg (390 lb)**, which is the maximum weight capacity.
- The luggage weight must not exceed **15.5 kg (34 lb)** under any circumstances.
- The fitting of large fork-mounted or large handlebar mounted fairing is not recommended.

Image Labels

Vehicle Safety

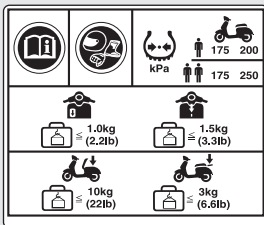

TYRE INFORMATION & CARGO LIMIT LABEL

For your protection, always wear helmet, protective apparel.

Cold tyre pressure:

[Driver only]

Front **175 kPa (1.75 kgf/cm², 25 psi)**

Rear **200 kPa (2.00 kgf/cm², 29 psi)**

[Driver and passenger]

Front **175 kPa (1.75 kgf/cm², 25 psi)**

Rear **250 kPa (2.50 kgf/cm², 36 psi)**

Cargo limit:

Glove box **1.0 kg (2.2 lb)**

Shopping hook **1.5 kg (3.3 lb)**

Centre compartment **10 kg (22 lb)**

Rear carrier **3 kg (6.6 lb)**



FUEL LABEL

Unleaded petrol only

ETHANOL up to 10 % by volume

Safety Precautions

Vehicle Safety

Safety Precautions

- Ride cautiously and keep your hands on the handlebar and feet on the floor.
- Keep passenger's hands onto the grab rail or your waist, passenger's feet on the footpegs while riding.
- Always consider the safety of your passenger, as well as other drivers and riders.

Protective Apparel

Make sure that you and any passenger are wearing an approved helmet, eye protection, and high-visibility protective clothing. Avoid wearing loose clothes that could get caught on any part of the vehicle. Ride defensively in response to weather and road conditions.

■ Helmet

Safety-standard certified, high-visibility, correct size for your head

- Must fit comfortably but securely, with the chin strap fastened.
- Face shield with unobstructed field of vision or other approved eye protection

⚠ WARNING

Not wearing a helmet increases the chance of serious injury or death in a crash.

Make sure that you and any passenger always wear an approved helmet and protective apparel.

■ Gloves

Full-finger leather gloves with high abrasion resistance

■ Boots or Riding Shoes

Sturdy boots with non-slip soles and ankle protection

■ Jacket and Trousers

Protective, highly visible, long-sleeved jacket and durable trousers for riding (or a protective suit)

Riding Precautions

Riding Precautions

Running-in Period

During the first 500 km (300 miles) of running, follow these guidelines to ensure your vehicle's future reliability and performance.

- Avoid full-throttle starts and rapid acceleration.
- Avoid hard braking.
- Ride conservatively.

Brakes

Observe the following guidelines:

- Avoid excessively hard braking.
 - ▶ Sudden braking can reduce the vehicle's stability.
 - ▶ Where possible, reduce speed before turning; otherwise you risk sliding out.
- Exercise caution on low traction surfaces.
 - ▶ The tyres slip more easily on such surfaces and braking distances are longer.

- Avoid continuous braking.
 - ▶ Repeated braking, such as when descending long, steep slopes can seriously overheat the brakes, reducing their effectiveness.
- For full braking effectiveness, operate both the front and rear brakes together.

Combi Brake

Your vehicle is equipped with a brake system that distributes the braking force between the front and rear brakes.

The distribution of the braking force applied to the front and rear brakes when operating the front brake lever only and when operating the rear brake lever only is different.

For full braking effectiveness, operate both the front and rear brakes together.

Riding Precautions

Wet or Rainy Conditions

Road surfaces are slippery when wet, and wet brakes further reduce braking efficiency. Exercise extra caution when braking in wet conditions.

If the brakes get wet, apply the brakes while riding at low speed to help them dry.

Parking

- Park on a firm, level surface.
- If you must park on a slight incline or loose surface, park so that the vehicle cannot move or fall over.
- Make sure that high-temperature parts cannot come into contact with flammable materials.
- Do not touch the engine, muffler, brakes and other high-temperature parts until they cool down.
- To reduce the likelihood of theft, always lock the handlebar, lock the ignition switch (▶ P. 41) and leave your vehicle while taking the Honda SMART Key with you. Deactivate the Honda SMART Key system if necessary. (▶ P. 36)
Use of an anti-theft device is also recommended.

Riding Precautions

■ Parking with the Side Stand or Centre Stand

1. Stop the engine.

2. Using the side stand

Push the side stand down.

Slowly lean the vehicle to the left until its weight rests on the side stand.

Using the centre stand

To lower the centre stand, stand on the left side of the vehicle.

Hold the left handle grip and the grab rail. Press down on the tip of the centre stand with your right foot and, simultaneously, pull up and back.

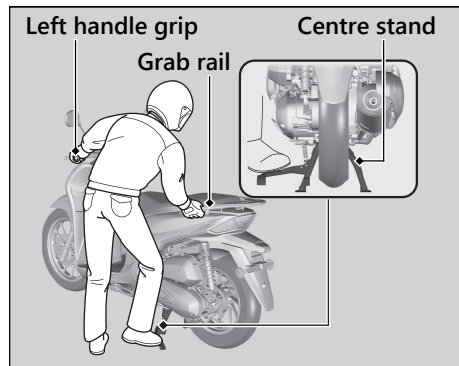

3. Turn the handlebar fully to the left.
 - ▶ Turning the handlebar to the right reduces stability and may cause the vehicle to fall.
4. Turn the ignition switch to the  (Lock) position (▶ P. 34) and lock the ignition switch (▶ P. 41).

Riding Precautions

Vehicle Safety

Refuelling and Fuel Guidelines

Follow these guidelines to protect the engine, fuel system and catalytic converter:

- Use only unleaded petrol.
- Use recommended octane number. Using lower octane petrol will result in decreased engine performance.
- Do not use fuels containing a high concentration of alcohol.  P. 136
- Do not use stale or contaminated petrol or an oil/petrol mixture.
- Avoid getting dirt or water in the fuel tank.

Accessories & Modifications

We strongly advise that you do not add any accessories that were not specifically designed for your vehicle by Honda or make modifications to your vehicle from its original design. Doing so can make it unsafe. Modifying your vehicle may also void your warranty and make your vehicle illegal to operate on public roads. Before deciding to install accessories on your vehicle, be certain the modification is safe and legal.

WARNING

Improper accessories or modifications can cause a crash in which you can be seriously hurt or killed.

Follow all instructions in this owner's manual regarding accessories and modifications.

Do not pull a trailer with, or attach a sidecar to, your vehicle. Your vehicle was not designed for these attachments, and their use can seriously impair your vehicle's handling.

Loading

Vehicle Safety

Loading

- Carrying extra weight affects your vehicle's handling, braking and stability. Always ride at a safe speed for the load you are carrying.
- Avoid carrying an excessive load and keep within specified load limits.
Maximum weight capacity / Maximum luggage weight  P. 138
- Tie all luggage securely, evenly balanced and close to the centre of the vehicle.
- Do not place objects near the lights or the muffler.

WARNING

Overloading or improper loading can cause a crash and you can be seriously hurt or killed.

Follow all load limits and other loading guidelines in this manual.

Vehicle Safety





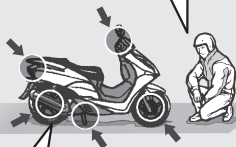

Basic Operation Flow

Pre-ride Inspection P.68

Carefully inspect your vehicle to make sure that it is safe to ride.



How to use basic features.

- Instruments  P.22
- Indicators  P.29
- Switches  P.32
- Steering Lock  P.34
- Answer Back System  P.43
- Honda SMART Key System  P.35
- Idling Stop System  P.45

Acceleration P.52

Apply throttle gradually.
Obey the speed limit.



Starting the Engine P.48

Start and warm the engine.
Avoid revving the engine.



Starting the Vehicle P.52

Before pulling away, indicate your direction with the turn signal switch, and check for oncoming traffic.



Braking → P.53

STOP!



Close the throttle and apply the front and rear brakes together.
▶ The brakelight will indicate that you have applied the brakes.

Parking → P.12

Park on a firm level surface. Use the stand, lock the steering.



Stopping

If pulling off the road, signal early enough to show traffic that you are pulling over, and pull over smoothly.



Turning Corners

Do your braking before entering corners.

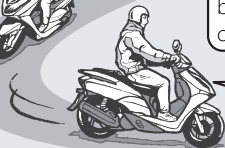

Gradually reapply throttle when exiting turn.

Refuelling → P.54

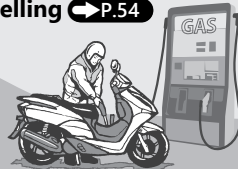

Parts Location

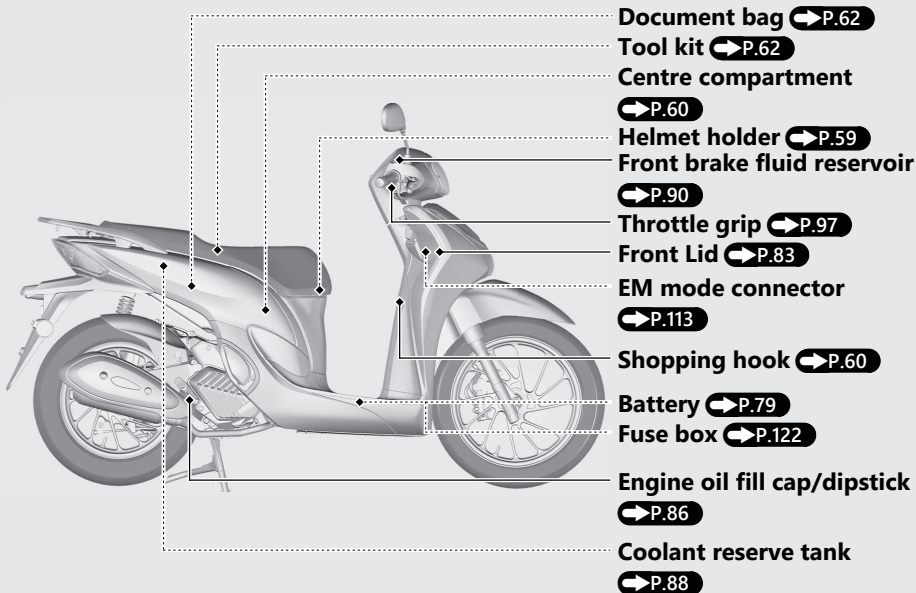

Data link connector

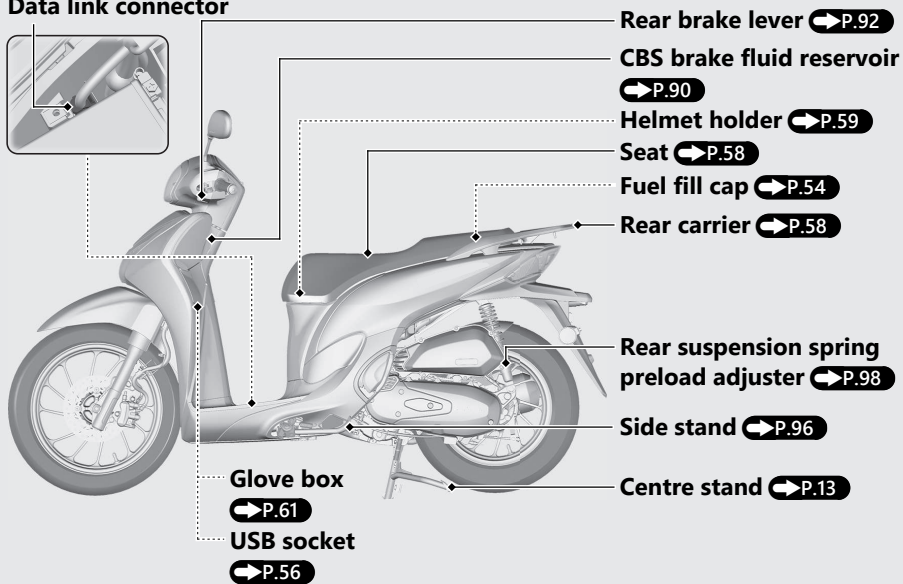
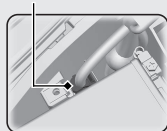

Instruments

Speedometer

This shows your speed in kilometer per hour (km/h) and/or miles per hour (mph) depend on type.

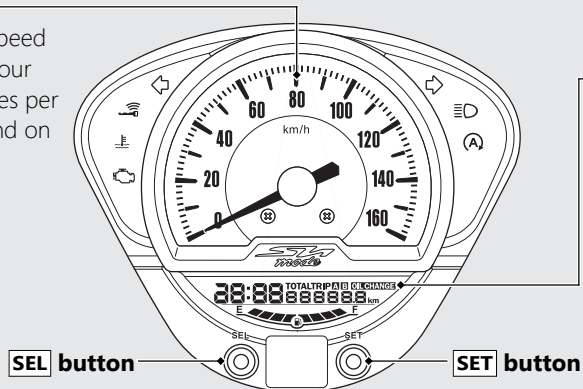

Display Check

When the ignition switch is turned to the **I** (On) position, all the mode and digital segments will show.

If any part of these displays does not come on when it should, have your dealer check for problems.

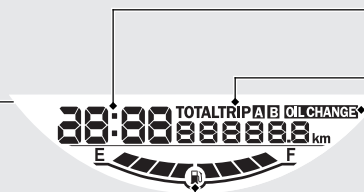

Clock (12-hour or 24-hour display)

To set the clock: **➡ P.25**

Odometer [TOTAL] & Tripmeter [TRIP A/B]

SEL button switches between the odometer and tripmeters.

- Odometer: Total distance ridden.
- Tripmeter: Distance ridden since tripmeter was reset (press and hold **SET** button to reset to 0.0 km while tripmeter A or B is displayed).

OIL CHANGE indicator ➡ P.24

Fuel gauge

Remaining fuel when there is only 1st (E) segment: approximately 1.51 L (0.399 US gal, 0.332 Imp gal)
 This segment flashes when the fuel decreases further.

NOTICE

You should refuel when the reading approaches the E (1st) segment. Running out of fuel can cause the engine to misfire, damaging the catalytic converter.



If the fuel gauge indicator flashes in a repeat pattern or turns off: ➡ P.106

Instruments *(Continued)*

OIL CHANGE indicator

The indicator is turned on whenever the running distance reaches the programed oil change interval.

When the OIL CHANGE indicator is appeared, reset the indicator after changing the engine oil.

- ▶ The OIL CHANGE indicator is appeared for the first time when the running distance reaches 1,000 km (600 miles).
- ▶ The OIL CHANGE indicator is appeared when the running distance reaches every 6,000 km (4,000 miles) after the first indication was reset.
- ▶ The indicator does not go off until it is reset.

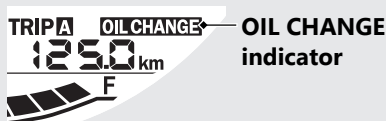

To reset the OIL CHANGE indicator

Press and hold the **SET** button while turning the ignition switch to the **I** (On) position, and keep holding the **SET** button for more than 3 seconds.

If the oil is changed before the oil change indicator comes on, be sure to reset the oil change indicator after changing the oil. When resetting the indicator during no indication, the indicator will appear for 2 seconds, then disappear.

Display Setting

Following items to change or reset sequentially.

- Time format setting
- Clock setting
- Backlight brightness adjustment
- **E type only**

Changing of mileage unit

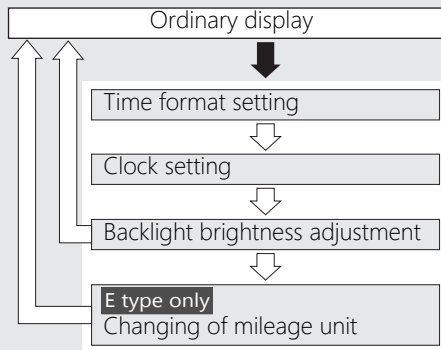

➡ Press and hold **SEL** button and **SET** button

⇨ Press the **SET** button

Instruments *(Continued)*

If the ignition switch is turned to the  (Off) position or the button is not pressed for about 30 seconds, the control is automatically switched from the setting mode to the ordinary display.

If the button is not pressed for about 30 seconds items in the process of being set will be discarded and only items where settings have been finalized will be applied.

Only if the ignition switch is turned to the  (Off) position will items in the process of being set and those that are finalized be applied.

1 Time format setting:

You can switch the time format between 12 hour format or 24 hour format.

- ① Turn the ignition switch to the  (On) position.
- ② Press and hold **SEL** button and **SET** button, the current time format start flashing.



- ③ Press the **SEL** button to select "12 hr" or "24 hr".



- ④ Press the **SET** button. The time format is set, and then the display moves to the clock setting.

2 Clock setting:

- 1 Press the **SEL** button until the desired hour is displayed.
 - ▶ Press and hold the **SEL** button to advance the hour fast.

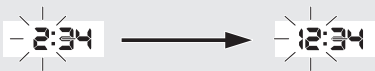

- 2 Press the **SET** button. The minute digits start flashing.

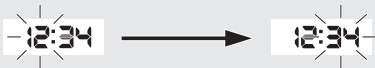

- 3 Press the **SEL** button until the desired minute is displayed.
 - ▶ Press and hold the **SEL** button to advance the minute fast.

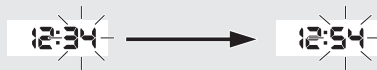

- 4 Press the **SET** button. The clock is set, and then the display moves to the backlight brightness adjustment.

Instruments *(Continued)***3 Backlight brightness adjustment:**

You can adjust the brightness to one of five levels.

- 1 Press the **[SEL]** button. The brightness is switched.



- 2 Press the **[SET]** button.

ED type only

The backlight is set, and then the display returns to the ordinary display.

E type only

The backlight is set, and then the display moves to the changing mileage unit.

4 Changing of mileage unit:

E type only

- 1 Press the **[SEL]** button to select either "km" or "mile".
- 2 Press the **[SET]** button. The mileage unit is set, and then the display returns to the ordinary display.



Indicators

If one of these indicators does not come on when it should, have your dealer check for problems.

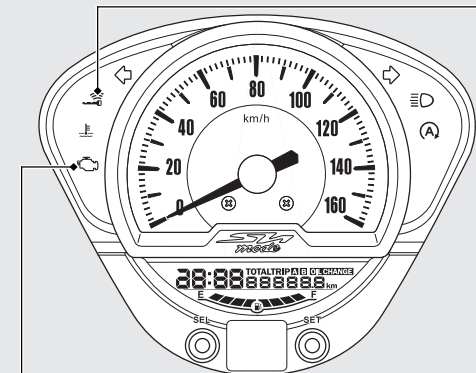

PGM-FI (Programmed Fuel Injection) malfunction indicator lamp (MIL)

Comes on briefly when the ignition switch is turned to the **I** (On) position.

If it comes on while engine is running:

 **P.104**

Honda SMART Key Indicator

Comes on when vehicle and Honda SMART Key verification is complete, and the ignition switch can be operated. Goes off when the ignition switch is turned to the **I** (On) position.

When the Honda SMART Key Indicator Flashes:  **P.105**

Indicators (Continued)

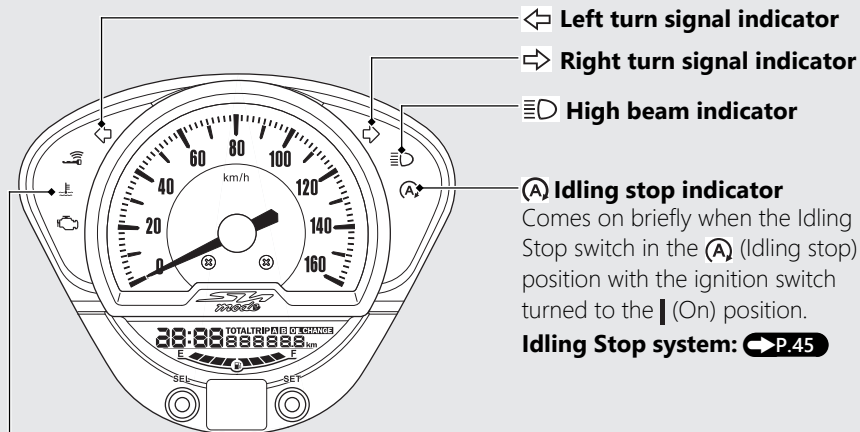

← **Left turn signal indicator**

→ **Right turn signal indicator**

≡ **High beam indicator**

(A) **Idling stop indicator**

Comes on briefly when the Idling Stop switch in the (A) (Idling stop) position with the ignition switch turned to the I (On) position.

Idling Stop system: → P.45

≡ **High coolant temperature indicator**

Comes on briefly when the ignition switch is turned to the I (On) position.

If it comes on while riding: → P.103

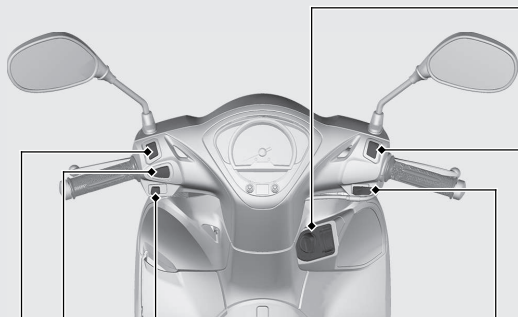

Switches





 **Turn signal switch**
▶ Pressing the switch turns the turn signal off.

 **Horn button**

Headlight dimmer switch

-  : High beam
-  : Low beam

Idling Stop switch

-  : The Idling Stop system is on.
-  : The Idling Stop system is off.

Idling Stop system:  **P.45**

 **Start button**

⏻ Ignition switch

Switches the electrical system on/off, locks the steering, and operates the seat opener switch.

▶ To unlock the ignition switch.

➡ P.40

🔊 Answer back button

This button is used to operate the answer back system.

Answer back System: ➡ P.43

📶 ON/OFF button

This button is used to activate or deactivate the Honda SMART Key system, and also to confirm the activation status. ➡ P.36

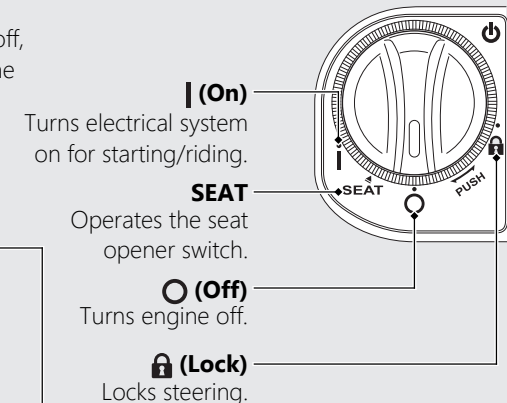

| (On)

Turns electrical system on for starting/riding.

SEAT

Operates the seat opener switch.

○ (Off)

Turns engine off.

🔒 (Lock)

Locks steering.

Switches *(Continued)*



Steering Lock

Lock the steering when parking to help prevent theft.

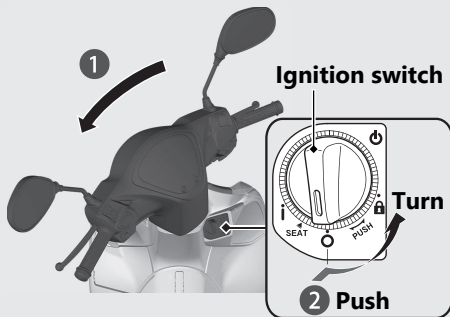
A U-shaped wheel lock or similar device is also recommended.





Locking

- ① Turn the handlebar all the way to the right or left.
- ② Push the ignition switch down, and turn the ignition switch to the  (Lock) position.
 - ▶ To unlock the ignition switch  P.40
 - ▶ Jiggle the handlebar if the lock is difficult to engage.
- ③ Lock the ignition switch.  P.41

Unlocking

Push the ignition switch in, and turn it to the

 (Off) position.

- ▶ To unlock the ignition switch  P.40

Honda SMART Key System

The Honda SMART Key system allows you to operate the main switch without inserting a key into a keyhole.

The system runs a two-way authentication between the vehicle and the Honda SMART Key to verify if it is the registered Honda SMART Key.

The Honda SMART Key system uses low-intensity radio waves. It may affect medical equipment such as a cardiac pacemaker.

Honda SMART Key System *(Continued)*

Switching the Honda SMART Key System

To switch the Honda SMART Key system to activation or deactivation

Press the ON/OFF button until the Honda SMART Key LED changes colour.

To check the Honda SMART Key system status

Lightly press the ON/OFF button. The Honda SMART Key LED will show the status.

When the Honda SMART Key LED is:

- | | |
|--------------------|--|
| Green:
(active) | Honda SMART Key system authentication can be performed. |
| Red:
(Inactive) | Honda SMART Key system authentication cannot be performed. |

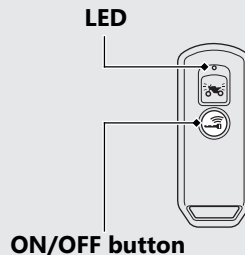

Operating Range

The operating range varies when the ignition switch is locked or unlocked.

The Honda SMART Key system uses low-intensity radio waves. Therefore, the operating range may be wider or narrower, or the Honda SMART Key system may not work properly in the following situations:

- When the Honda SMART Key battery is depleted.
- When there are facilities nearby that generate strong radio waves or noise, such as TV towers, power stations, radio stations, or airports.
- When you carry the Honda SMART Key with a laptop or wireless communication device such as a radio or mobile phone.
- When the Honda SMART Key comes into contact with or is covered by metal objects.

When the ignition switch is unlocked:

The system can be operated within the shaded area shown in the illustration.

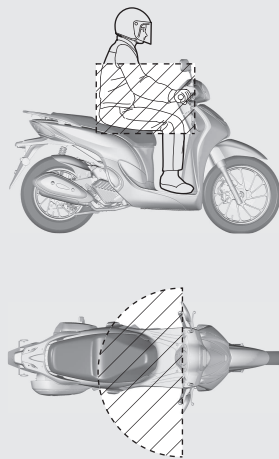

Honda SMART Key System *(Continued)*

When the ignition switch is locked:

The system can be operated within the shaded area shown in the illustration.

About 2 m (6.6 ft)

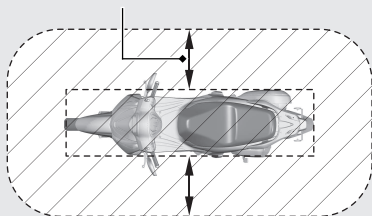

Anyone can unlock the ignition switch and start the engine if your Honda SMART Key is within operating range of your vehicle, even if you are on the other side of a wall or window. If you are away from your vehicle but your Honda SMART Key is still within operating range, deactivate the Honda SMART Key system.

To switching the Honda SMART Key system ➔ **P.36**

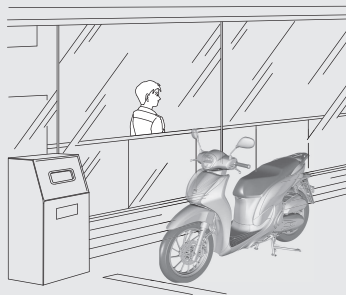

Anyone in possession of the Honda SMART Key can perform the following operations if the Honda SMART Key is within operating range:

- Starting the engine
- Unlocking the ignition switch
- Releasing the seat lock
- Unlocking the steering lock

You should always keep the Honda SMART Key on your person after you get on and off the vehicle or while riding.

Do not place the Honda SMART Key in the any compartment.

If the ignition switch is in the **I** (On) position, the vehicle can be operated even by a person who does not have a verified Honda SMART Key.

Whenever you leave your vehicle, lock the steering and lock the ignition switch.

▶ P.41

Make sure the ignition switch ring goes off and all turn signals flash once at this time.

Honda SMART Key System (Continued)

Switching the ignition switch

To Unlock the Ignition Switch

- 1 Make sure that the Honda SMART Key system is activated. ➔P.36
- 2 To authenticate the Honda SMART Key system, push the ignition switch.
 - ▶ When properly authenticated and the ignition switch is unlocked, the Honda SMART Key indicator and ignition switch ring come on.
- 3 Turn the ignition switch to the **I** (On) position while the Honda SMART Key indicator comes on.
 - ▶ If you do not turn the ignition switch to the **I** (On) position within 20 seconds after pushing in the ignition switch, the Honda SMART Key indicator and ignition switch ring will go off, the turn signals flash 1 time, and then the ignition switch will be locked.

When the Honda SMART Key system does not work properly ➔P.110

If someone without the Honda SMART Key tries to turn the ignition switch, the ignition switch rotates freely. If you notice the ignition switch is in a different position, turn the ignition switch to the original **O** (Off) or **L** (Lock) position.



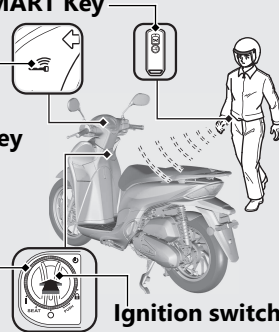

Honda SMART Key

Honda SMART Key indicator

Ignition switch ring



To Lock the Ignition Switch

- 1 Turn the ignition switch to the SEAT, ○ (Off) or  (Lock) position.
- 2 Lock the ignition switch by doing one of the following:
 - Leave the operating range with the Honda SMART Key.  **P.38**
 - Push the ignition switch.
 - Wait for approximately 20 seconds after turning the ignition switch from  (On) to SEAT, ○ (Off) or  (Lock) position.
 - Switch the Honda SMART Key system to inactive.  **P.36**
- 3 Make sure that the Honda SMART Key indicator and ignition switch ring go off, the turn signals flash once. This indicates that the ignition switch is locked.

When the Honda SMART Key system does not work properly **P.110**

Ignition switch ring

Ignition switch

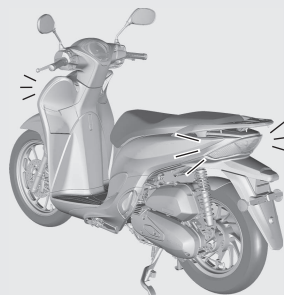
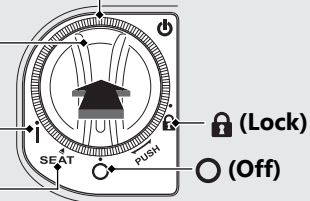

 (On)

SEAT



Continued 41

Honda SMART Key System *(Continued)*

Always make sure the ignition switch position is in the  (Off) or  (Lock) position when you leave your vehicle.

When the ignition switch is locked in the SEAT position, the ignition switch can be turned to the  (Off) position only once.

When the ignition switch is locked in the  (Off) position, the steering cannot be locked. To lock the steering, unlock the ignition switch.

Answer Back System

The answer back system is a device to find the location of your vehicle. When the immobilizer is active and you press the answer back button on the Honda SMART Key with the ignition switch in the **○** (Off) or **🔒** (Lock) position, the turn signals light, and the ignition switch ring lights, informing you of your vehicle's location. The ignition switch ring will light for about 1 minute.

The answer back system uses low-intensity radio waves. It may affect medical equipment such as a cardiac pacemaker.

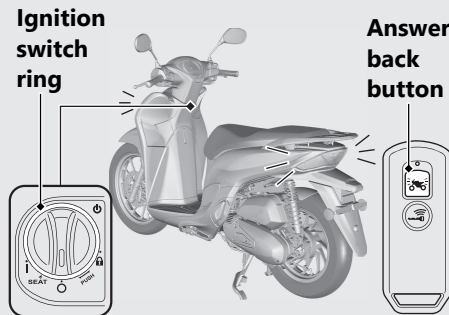

Answer Back System *(Continued)*

Operation

Press the answer back button on the Honda SMART Key.

- ▶ The answer back system will not function when the ignition switch is in the **I** (On) position.

If the ignition switch is left in the **O** (Off) or **A** (Lock) position for more than 10 days, the answer back system will no longer operate. When the system is active and the vehicle receives a signal from pressing answer back or alarm button, system activation will be extended for 10 days.

To reset the system, turn the ignition switch to the **I** (On) position once.

- ▶ To unlock the ignition switch  **P.40**

When the battery in the vehicle is weak, the answer back system may not function.

Idling Stop System

Idling Stop system is designed to help reduce the fuel consumption and noise, by idling stop while making a stop such as waiting at an intersection.

Switching the Idling Stop System On or Off

Switches the Idling Stop system on or off using the Idling Stop switch.

- ON: (A) **(Idling Stop)**
 - ▶ Idling Stop indicator comes on when the Idling Stop system becomes ready to stop the engine while riding. Idling Stop indicator flashes when the engine is stopped by the Idling Stop system.
- OFF: (A) **(Idling)**
 - ▶ Idling Stop indicator does not come on when the Idling Stop system is off.

Activation of the Idling Stop System

The Idling Stop system becomes ready to stop the engine and Idling Stop indicator comes on when the following requirements are satisfied with the Idling Stop switch in the (A) (Idling Stop) position:

- start the engine by pressing the start button
- warm up the engine enough
- ride the vehicle at speeds over 10 km/h (6 mph)

Idling Stop Indicator Does Not Come On: → P.107

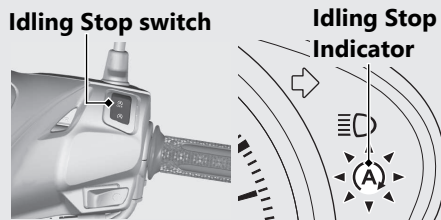

Continued 45

Idling Stop System *(Continued)*

Stopping the engine by the Idling Stop System

The engine stops and Idling Stop indicator changes to flash after you close the throttle completely and stop the vehicle while the Idling Stop indicator is on.

- ▶ While the engine is stopped by the Idling Stop system, if you press the Idling Stop switch to  (Idling), the Idling Stop system will be cancelled. The engine will not restart even when you open the throttle.



Safety Precaution for the Idling Stop System

Do not go away from the vehicle while the Idling Stop indicator is flashing. When you go away from the vehicle, always turn the ignition switch to the  (Off) position.

- ▶ The engine may start unexpectedly if the throttle is opened.

Engine is Not Stopped by the Idling Stop System While the Idling Stop Indicator is On:

NOTICE

Stopping by the Idling Stop system for a long time may cause battery discharge.

Restarting the Engine

Check that the Idling Stop indicator is flashing, and then open the throttle.

- ▶ If it is not flashing, you can't restart the engine with the Idling Stop system, even if you open the throttle.
- ▶ While the engine is stopped by the Idling Stop system, if you operate the side stand, the flashing Idling Stop indicator turns off or stops flashing and stays on, then the engine will not restart even when you open the throttle.

Engine Does Not Start Even If the Throttle is Opened:  **P.109**

NOTICE

Headlight stays on after the engine is stopped by the Idling Stop system. The battery may discharge and you may not be able to restart engine.

When the battery is weak, switch the Idling Stop switch to  (Idling) and do not to use the Idling Stop system. See your dealer to check the battery.

See your dealer for checking the battery as specified in the maintenance schedule.

Maintenance Schedule:  **P.65**

Starting the Engine

Start your engine using the following procedure, regardless of whether the engine is cold or warm.

This vehicle is equipped with a side stand ignition cut-off system.

- ▶ If the side stand is down, the engine cannot be started.
- ▶ If you lower the side stand with the engine running, it will automatically shut off.

This vehicle is equipped with a Honda SMART Key system. Always keep Honda SMART Key on you when you ride the vehicle. **→P.37**

If the engine of this vehicle is stopped while the ignition switch is in the **I** (On) position, authentication will be disabled after a certain amount of time or if you leave the authentication range. Restart the engine by performing step **3** & **4** under the starting procedure.

- ▶ If the engine of this vehicle is stopped by the Idling Stop System, authentication will not be disabled.

NOTICE

- If the engine does not start within 5 seconds, turn the ignition switch to the **O** (Off) position and wait 10 seconds before trying to start the engine again to recover battery voltage.
- Extended fast idling and revving the engine can damage the engine, and the exhaust system.
- If the vehicle is over-turned, you must first turn the ignition switch to the **O** (Off) position and then inspect the vehicle carefully.

- 1 Place the vehicle on its centre stand.
- 2 Turn the ignition switch to the **I** (On) position.
 - ▶ To unlock the ignition switch. **→P.40**
 Confirm the following:
 - The PGM-FI malfunction indicator lamp (MIL) is off.
 - The high coolant temperature indicator is off.

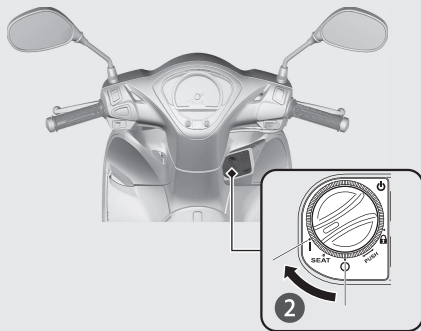

- 3 Squeeze the rear brake lever.
 - ▶ The starter motor will only work when the rear brake lever is squeezed and the side stand is up.
- 4 Press the start button with the throttle completely closed. Release the start button as soon as the engine starts.

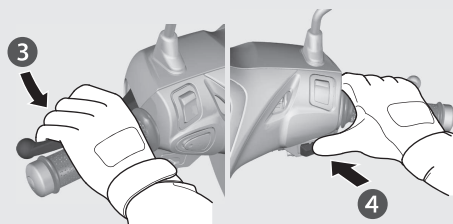

Starting the Engine *(Continued)*

If you cannot start the engine:

With the throttle slightly open (about 3 mm without freeplay), press the start button.

**About 3 mm,
without freeplay**

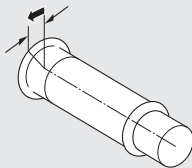

If you cannot start a warm engine:

Rotate the throttle 1/8 - 1/4 turn while starting the engine.

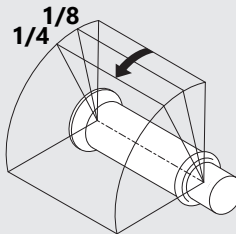

If the engine does not start:

- ① Open the throttle fully and press the start button for 5 seconds.
- ② Repeat the normal starting procedure.
- ③ If the engine starts, open the throttle slightly if idling is unstable.
- ④ If the engine does not start, wait 10 seconds before trying steps ① & ② again.

If Engine Will Not Start ➔ P.102

Riding

Starting the Vehicle

① Push the vehicle forward off the centre stand.

- ▶ Squeeze the rear brake lever.
- ▶ Keep throttle closed.

Make sure the side stand and centre stand are up.

② Get on the vehicle.

- ▶ Mount the vehicle from the left side, keeping at least one foot on the ground.

③ Release the brake lever.

④ Acceleration and deceleration

To accelerate: Open the throttle slowly.

To decelerate: Close the throttle.

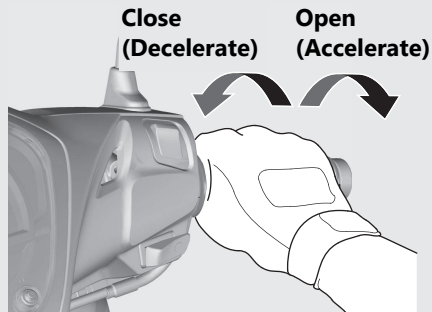

Braking

Close the throttle and apply the front and rear brake levers together.

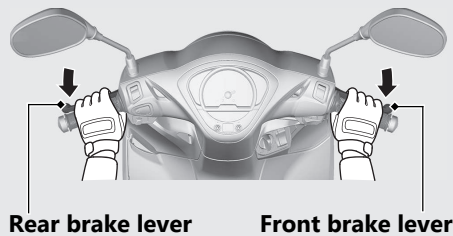

Refuelling

Fuel type: Unleaded petrol only

Fuel octane number: Your vehicle is designed to use Research Octane Number (RON) 95 or higher.

Tank capacity: 5.6 L (1.48 US gal, 1.23 Imp gal)

Refuelling and Fuel Guidelines ➔ P.14

Opening the Fuel Fill Cap

- 1 Open the seat. ➔ P.58
- 2 Turn the fuel fill cap counterclockwise until it stops and remove the fuel fill cap.

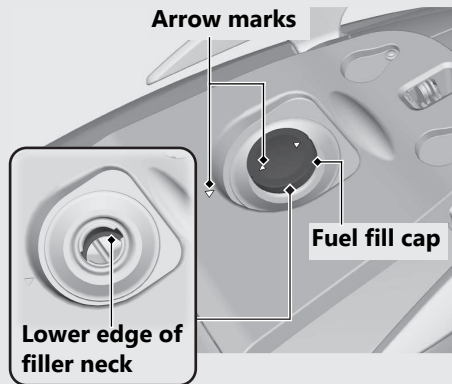

Do not fill with fuel above the lower edge of the filler neck.

Closing the Fuel Fill Cap

- ① Install and tighten the fuel fill cap firmly by turning it clockwise.
 - ▶ Make sure that the arrow marks on the fuel fill cap and fuel tank are aligned.
- ② Close the seat.

WARNING

Petrol is highly flammable and explosive. You can be burned or seriously injured when handling fuel.

- Stop the engine, and keep heat, sparks, and flame away.
- Handle fuel only outdoors.
- Wipe up spills immediately.

USB Socket

The USB socket is located in the glove box. Use USB devices at your own risk. In no event shall Honda be liable for any damage to your USB device when in use.

Only USB devices within the following specifications can be connected. Open the cover to access the USB socket.

Rated capacity is

7.5 W (5 V, 1.5 A).

Do not connect USB devices that exceed the rated capacity. They may not be charged or work properly even if connected.

For information on usage or malfunction of the USB device you connect, refer to its instruction manual.

To connect your USB device

- 1 Open the glove box lid. ➔ P.61
- 2 Open the cover to access the USB socket.

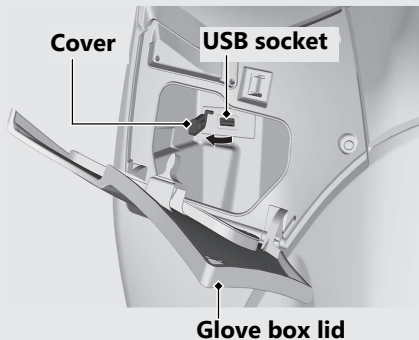

- 3 Connect a certified USB cable to the USB socket.

- ▶ To prevent the battery from becoming weak (or dead), keep the engine running while drawing current from the USB socket.
- ▶ To prevent entry of foreign matter into the USB socket, be sure to close the cover when the USB socket is not used.
- ▶ Carefully secure all connected devices, as vibration may cause damage to them or they could shift unexpectedly.

NOTICE

- Using any heat-generating USB devices or improperly rated USB devices can damage the USB socket.
- Do not use the USB socket in wet conditions, when or while washing or any other wet conditions as these will damage the USB socket.
- Do not allow the USB's harness to become pinched or trapped.

Storage Equipment

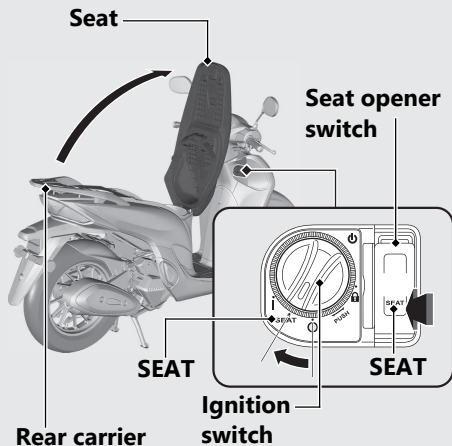

Rear carrier

Never exceed the maximum weight limit.

Maximum Weight: 3 kg (6.6 lb)

Seat Open

- ① Turn the handlebar pointed straight ahead.
- ② Turn the ignition switch to the SEAT position.
 - ▶ To unlock the ignition switch → P.40
- ③ Push the SEAT side of the seat opener switch.
- ④ Open the seat.

Seat Close

Close and push down on the rear of the seat until locks. Make sure that the seat is locked securely to pull it up lightly. Take care not to lock your key in the compartment under the seat.

Helmet Holder

The helmet holders are located under the seat.

- ▶ Use the helmet holders only when parked.

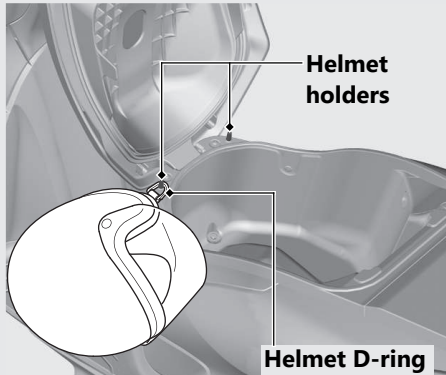

⚠WARNING

Riding with a helmet attached to the holder can interfere with your ability to safely operate the vehicle and could lead to a crash in which you can be seriously hurt or killed.

Use the helmet holder only while parked. Do not ride with a helmet secured by the holder.

Storage Equipment *(Continued)*

A helmet can be stored in the centre compartment.

Set in the front of the helmet forward.

- ▶ Some helmets may not fit in the compartment due to their size or design.

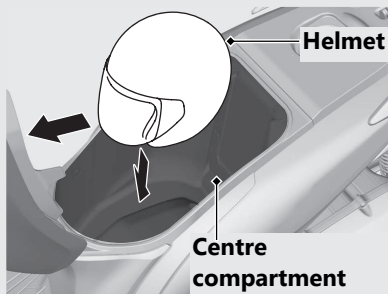

Centre compartment

Never exceed the maximum weight limit.

Maximum Weight: 10 kg (22 lb)

- ▶ Do not store any items that are flammable or susceptible to heat damage.
- ▶ Do not store valuables or fragile articles.

Shopping Hook

The shopping hook is provided below the handlebar.

- ▶ Do not attach large luggage to the hook that would hang out from the vehicle and/or interfere with the movement of your feet.



The maximum allowable load on the shopping hook shall be no more than **1.5 kg (3.3 lb)**.

Glove Box

The glove box is provided below the handlebar.

Glove box lid

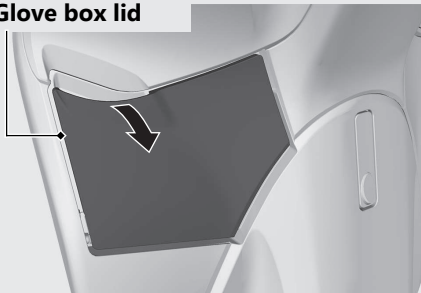

Open

Pull the glove box lid.

Close

Press forward the glove box lid until it is firmly closed.

The maximum allowable load on the glove box shall be no more than **1.0 kg (2.2 lb)**.

- ▶ Do not store valuables or fragile articles.

Storage Equipment *(Continued)*

Tool Kit

The tool kit is in the reverse side of the seat by the rubber strap.

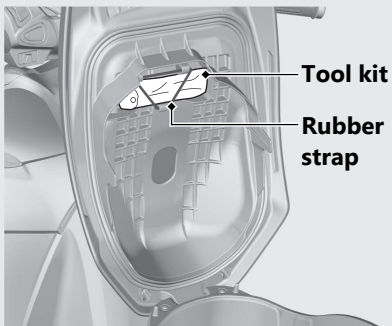

Document Bag

The document bag is in the document compartment in the centre compartment.

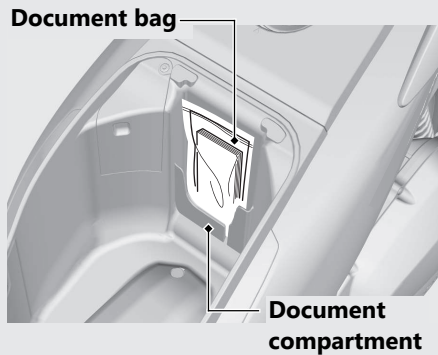

Maintenance

Please read “Importance of Maintenance” and “Maintenance Fundamentals” carefully before attempting any maintenance. Refer to “Specifications” for service data.

Importance of Maintenance	P. 64	Brakes	P. 90
Maintenance Schedule	P. 65	Side Stand	P. 96
Maintenance Fundamentals	P. 68	Throttle	P. 97
Tool	P. 78	Other Adjustments	P. 98
Removing & Installing Body Components ..	P. 79	Adjusting the Rear Suspension	P. 98
Battery	P. 79	Other Replacement	P. 99
Battery Cover	P. 80	Replacing the Honda SMART Key Battery	P. 99
Battery Lid	P. 81		
Clip	P. 82		
Front Lid	P. 83		
Fuel Tank Cover and Rear Centre Cover	P. 84		
Maintenance Lid	P. 85		
Engine Oil	P. 86		
Coolant	P. 88		

Importance of Maintenance

Importance of Maintenance

Keeping your vehicle well-maintained is absolutely essential to your safety and to protect your investment, obtain maximum performance, avoid breakdowns, and reduce air pollution. Maintenance is the owner's responsibility. Be sure to inspect your vehicle before each ride, and perform the periodic checks specified in the Maintenance Schedule.

➤ P. 65

⚠WARNING

Improperly maintaining your vehicle or failing to correct a problem before you ride can cause a crash in which you can be seriously hurt or killed.

Always follow the inspection and maintenance recommendations and schedules in this owner's manual.

Maintenance Safety

Always read the maintenance instructions before you begin each task, and make sure that you have the tools, parts, and skills required. We cannot warn you of every conceivable hazard that can arise in performing maintenance. Only you can decide whether or not you should perform a given task.

Follow these guidelines when performing maintenance.

- Stop the engine and turn the ignition switch to the **O** (Off) position.
- Place your vehicle on a firm, level surface using the side stand, centre stand or a maintenance stand to provide support.
- Allow the engine, muffler, brakes, and other high-temperature parts to cool before servicing as you can get burned.
- Run the engine only when instructed, and do so in a well-ventilated area.

Maintenance Schedule

The maintenance schedule specifies the maintenance requirements necessary to ensure safe, dependable performance, and proper emission control.

Maintenance work should be performed in accordance with Honda's standards and specifications by properly trained and equipped technicians. Your dealer meets all of these requirements. Keep an accurate record of maintenance to help ensure that your vehicle is properly maintained.

Make sure that whomever performs the maintenance completes this record.

All scheduled maintenance is considered a normal owner operating cost and will be charged to you by your dealer. Retain all receipts. If you sell the vehicle, these receipts should be transferred with the vehicle to the new owner.

Honda recommends that your dealer should road test your vehicle after each periodic maintenance is carried out.

Maintenance Schedule

Items	Pre-ride Check ☑ P. 68	Frequency *1									Annual Check	Regular Replace	Refer to page	
		× 1,000 km	1	6	12	18	24	30	36					
		× 1,000 mi	0.6	4	8	12	16	20	24					
Fuel Line	↗			I	I	I	I	I	I	I	I			-
Fuel Level	I													-
Throttle Operation	↗	I		I	I	I	I	I	I	I	I			97
Air Cleaner *2	↗						R				R			-
Crankcase Breather *3				C	C	C	C	C	C	C	C			-
Spark Plug				I	R	I	R	I	R	I	R			-
Valve Clearance	↗			I	I	I	I	I	I	I	I			-
Engine Oil	I		R	R	R	R	R	R	R	R	R	R		-
Engine Oil Strainer Screen						C		C		C				-
Engine Idle Speed	↗		I	I	I	I	I	I	I	I	I	I		-
Radiator Coolant *4	I					I		I		I	I	I	3 Years	88
Cooling System	↗					I		I		I	I	I		-
Evaporative Emission Control System	↗							I			I			-

Maintenance Level

- ↗ : Intermediate. We recommend service by your dealer, unless you have the necessary tools and are mechanically skilled.
Procedures are provided in an official Honda Shop Manual.
- ↘ : Technical. In the interest of safety, have your vehicle serviced by your dealer.

Maintenance Legend

- I : Inspect (clean, adjust, lubricate, or replace, if necessary)
R : Replace
C : Clean

Maintenance Schedule

Items	Pre-ride Check P. 68	Frequency *1								Annual Check	Regular Replace	Refer to page
		× 1,000 km	1	6	12	18	24	30	36			
		× 1,000 mi	0.6	4	8	12	16	20	24			
Drive Belt	↗				■			■	■			–
Final Drive Oil *4	↗										2 Years	–
Battery	↗			■	■	■	■	■	■	■		70
Brake Fluid *4	■			■	■	■	■	■	■	■	2 Years	90
Brake Shoes/Pads Wear	■			■	■	■	■	■	■	■		91, 95
Brake System	■			■	■	■	■	■	■	■		68
Headlight Aim				■	■	■	■	■	■	■		–
Lights/Horn	■											–
Clutch Shoes Wear	✗				■			■		■		–
Side Stand	■			■	■	■	■	■	■	■		96
Suspension	↗			■	■	■	■	■	■	■		98
Nuts, Bolts, Fasteners	↗				■			■		■		–
Wheels/Tyres	✗	■		■	■	■	■	■	■	■		75
Steering Head Bearings	✗				■			■		■		–

Notes:

*1 : At higher odometer reading, repeat at the frequency interval established here.

*2 : Service more frequently when riding in unusually wet or dusty areas.

*3 : Service more frequently when riding in rain or at full throttle.





*4 : Replacement requires mechanical skill.







Maintenance Fundamentals

Pre-ride Inspection

To ensure safety, it is your responsibility to perform a pre-ride inspection and make sure that any problem you find is corrected. A pre-ride inspection is a must, not only for safety, but because having a breakdown, or even a flat tyre, can be a major inconvenience.

Check the following items before you get on your vehicle:

- Fuel level - Fill fuel tank when necessary.  P. 54
- Throttle - Check for smooth opening and full closing in all steering positions.  P. 97
- Engine oil level - Add engine oil if necessary. Check for leaks.  P. 86
- Coolant level - Add coolant if required. Check for leaks.  P. 88

- Brakes - Check operation;
Front: check brake fluid level and pads wear.  P. 90,  P. 91
Rear: check shoes wear and freeplay, adjust if necessary.  P. 92,  P. 95
Combi Brake: check brake fluid level.  P. 90
- Lights and horn - Check that lights, indicators and horn function properly.
- Side stand ignition cut-off system - Check for proper function.  P. 96
- Wheels and tyres - Check condition, air pressure and adjust if necessary.  P. 75

Replacing Parts

Always use Honda Genuine Parts or their equivalents to ensure reliability and safety. When ordering coloured components, specify the model name, colour, and code mentioned on the colour label.

The colour label is attached to the centre compartment under the seat.  P. 58

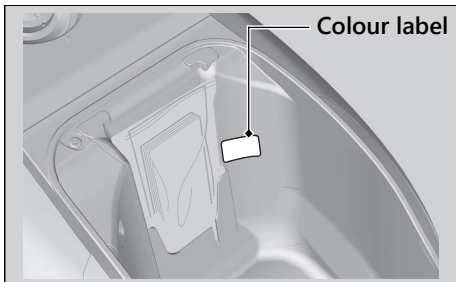

WARNING

Installing non-Honda parts may make your vehicle unsafe and cause a crash in which you can be seriously hurt or killed.

Always use Honda Genuine Parts or equivalents that have been designed and approved for your vehicle.

Maintenance Fundamentals

Battery

Your vehicle has a maintenance-free type battery. You do not have to check the battery electrolyte level or add distilled water. Clean the battery terminals if they become dirty or corroded.

Do not remove the battery cap seals. There is no need to remove the cap when charging.

NOTICE

Your battery is a maintenance-free type and can be permanently damaged if the cap strip is removed.



This symbol on the battery means that this product must not be treated as household waste.

NOTICE

An improperly disposed of battery can be harmful to the environment and human health. Always confirm local regulations for proper battery disposal instruction.

What to do in an emergency

If any of the following occur, immediately see your doctor.

- Electrolyte splashes into your eyes:
 - ▶ Wash your eyes repeatedly with cool water for at least 15 minutes. Using water under pressure can damage your eyes.
- Electrolyte splashes onto your skin:
 - ▶ Remove affected clothing and wash your skin thoroughly using water.
- Electrolyte splashes into your mouth:
 - ▶ Rinse mouth thoroughly with water, and do not swallow.

Maintenance Fundamentals

⚠WARNING

The battery gives off explosive hydrogen gas during normal operation.

A spark or flame can cause the battery to explode with enough force to kill or seriously hurt you.

Wear protective clothing and a face shield, or have a skilled mechanic do the battery servicing.

| Cleaning the Battery Terminals

1. Remove the battery.  P. 79
2. If the terminals are starting to corrode and are coated with a white substance, wash with warm water and wipe clean.

3. If the terminals are heavily corroded, clean and polish the terminals with a wire brush or sandpaper. Wear safety glasses.

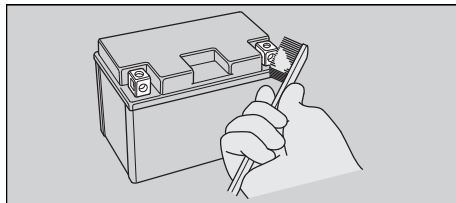

4. After cleaning, reinstall the battery.

The battery has a limited life span. Consult your dealer about when you should replace the battery. Always replace the battery with another maintenance-free battery of the same type.

NOTICE

Installing non-Honda electrical accessories can overload the electrical system, discharging the battery and possibly damaging the system.

Maintenance Fundamentals

Fuses

Fuses protect the electrical circuits on your vehicle. If something electrical on your vehicle stops working, check for and replace any blown fuses. 📄 P. 122

Inspecting and Replacing Fuses

Turn the ignition switch to the  (Off) position to remove and inspect fuses. If a fuse is blown, replace with a fuse of the same rating. For fuse ratings, see “Specifications.” 📄 P. 140

Blown fuse

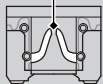

NOTICE

Replacing a fuse with one that has a higher rating greatly increases the chance of damage to the electrical system.

If a fuse fails repeatedly, you likely have an electrical fault. Have your vehicle inspected by your dealer.

Engine Oil

Engine oil consumption varies and oil quality deteriorates according to riding conditions and time elapsed.

Check the engine oil level regularly, and add the recommended engine oil if necessary. Dirty oil or old oil should be changed as soon as possible.

Selecting the Engine Oil

For recommended engine oil, see “Specifications.” 📄 P. 139

If you use non-Honda engine oil, check the label to make sure that the oil satisfies all of the following standards:

- JASO T 903 standard*1: MB
- SAE standard*2: 10W-30
- API classification*3: SG or higher

Maintenance Fundamentals

- *1. The JASO T 903 standard is an index for engine oils for 4-stroke motorcycle engines. There are two classes: MA and MB. For example, the following label shows the MB classification.

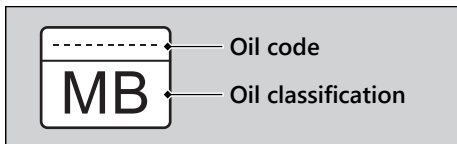

- *2. The SAE standard grades oils by their viscosity.
 *3. The API classification specifies the quality and performance rating of engine oils. Use SG or higher oils, excluding oils marked as "Energy Conserving" or "Resource Conserving" on the circular API service symbol.

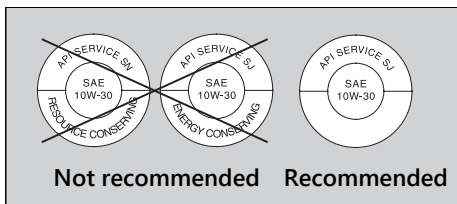

Brake Fluid

Do not add or replace brake fluid, except in an emergency. Use only fresh brake fluid from a sealed container. If you do add fluid, have the brake system serviced by your dealer as soon as possible.

NOTICE

Brake fluid can damage plastic and painted surfaces.
 Wipe up spills immediately and wash thoroughly.

Recommended brake fluid:

Honda DOT 3 or DOT 4 Brake Fluid or equivalent

Maintenance Fundamentals

Recommended Coolant

Pro Honda HP Coolant is a pre-mixed solution of antifreeze and distilled water.

Concentration:

50% antifreeze and 50% distilled water

A concentration of antifreeze below 40% will not provide proper corrosion and cold temperature protection.

A concentration of up to 60% will provide better protection in colder climates.

NOTICE

Using coolant not specified for aluminium engines or tap/mineral water can cause corrosion.

Crankcase Breather

Service more frequently when riding in rain, at full throttle, or after the vehicle is washed or overturned. Service if the deposit level can be seen in the transparent section of the drain tube.

If the drain tube overflows, the air filter may become contaminated with engine oil causing poor engine performance.

Maintenance Fundamentals

Tyres (Inspecting/Replacing)

Checking the Air Pressure

Visually inspect your tyres and use an air pressure gauge to measure the air pressure at least once a month or any time you think the tyres look low. Always check air pressure when your tyres are cold.

Inspecting for Damage

Inspect the tyres for cuts, slits, or cracks that exposes fabric or cords, or nails or other foreign objects embedded in the side of the tyre or the tread.

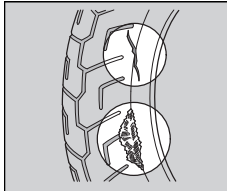

Also inspect for any unusual bumps or bulges in the side walls of the tyres.

Inspecting for Abnormal Wear

Inspect the tyres for signs of abnormal wear on the contact surface.

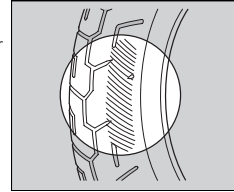

Maintenance Fundamentals

Inspecting Tread Depth

Inspect the tread wear indicators. If they become visible, replace the tyres immediately.

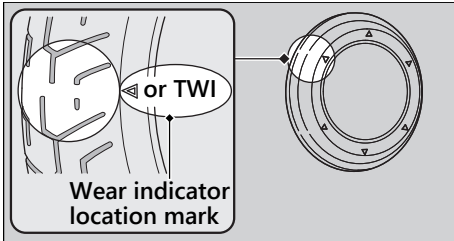

Maintenance

⚠ WARNING

Riding on tyres that are excessively worn or improperly inflated can cause a crash in which you can be seriously hurt or killed.

Follow all instructions in this owner's manual regarding tyre inflation and maintenance.

Maintenance Fundamentals

Have your tyres replaced by your dealer.
For recommended tyres and air pressure, see
“Specifications.” P. 139
Follow these guidelines whenever you replace
tyres.

- Use the recommended tyres or equivalents
of the same size, construction, speed rating,
and load range.
- Do not install a tube inside a tubeless tyre
on this vehicle. Excessive heat build-up can
cause the tube to burst.
- Use only tubeless tyres on this vehicle.
The rims are designed for tubeless tyres,
and during hard acceleration or braking, a
tube-type tyre could slip on the rim and
cause the tyre to rapidly deflate.

WARNING

Installing improper tyres on your
vehicle can adversely affect handling
and stability, and can cause a crash in
which you can be seriously hurt or
killed.

Always use the size and type of tyres
recommended in this owner's manual.

Tool

The tool kit is in reverse side of the seat.  P. 62

You can perform some roadside repairs, minor adjustments and parts replacement with the provided tools.

Maintenance

- 8 × 12 mm Open end wrench
- 10 × 14 mm Open end wrench
- Pin spanner
- Extension bar
- Standard/Phillips screwdriver
- Screwdriver handle
- EM mode coupler

Removing & Installing Body Components

Battery

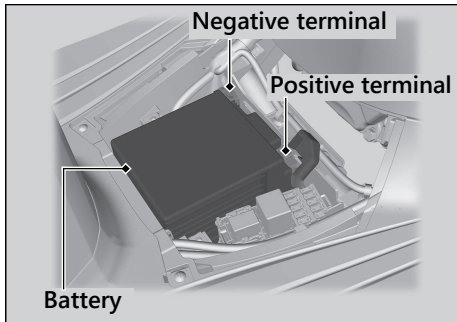

Removal

Make sure the ignition switch is in the **O** (Off) position.

1. Remove the battery cover. ➤ P. 80
2. Disconnect the negative \ominus terminal from the battery.
3. Disconnect the positive \oplus terminal from the battery.
4. Remove the battery taking care not to drop the terminal nuts.

Installation

Install the parts in the reverse order of removal. Always connect the positive \oplus terminal first. Make sure that bolts and nuts are tight.

Make sure the clock information is correct after the battery is reconnected. ➤ P. 25
For proper handling of the battery, see "Maintenance Fundamentals." ➤ P. 70
"Battery Goes Dead." ➤ P. 117

Removing & Installing Body Components ► Battery Cover

Battery Cover

Maintenance

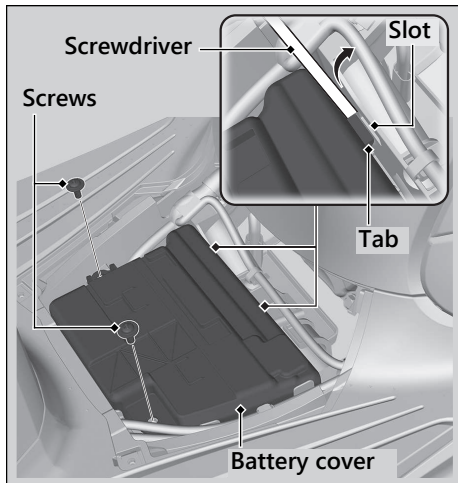

Removal

1. Remove the battery lid. ▣ P. 81
2. Remove the screws.
3. Use a flat head screwdriver to increase the gap and release the tabs from their slots.
4. Remove the battery cover.

Installation

Install the parts in the reverse order of removal.

Removing & Installing Body Components ► Battery Lid

Battery Lid

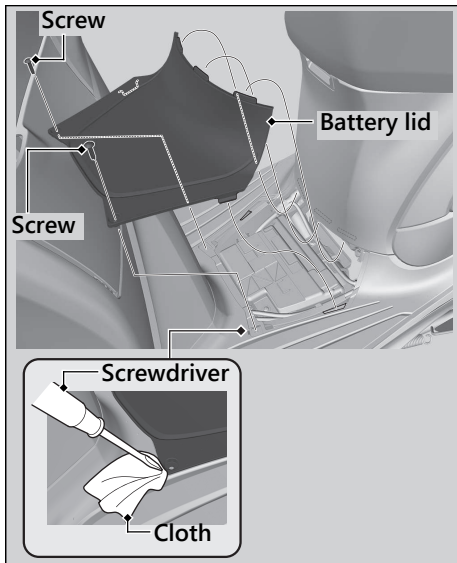

Removal

1. Remove the screws.
2. Remove the battery lid by using a flat head screwdriver covered with a protective cloth.

Installation

Install the parts in the reverse order of removal.

Removing & Installing Body Components ► Clip

Clip

Removal

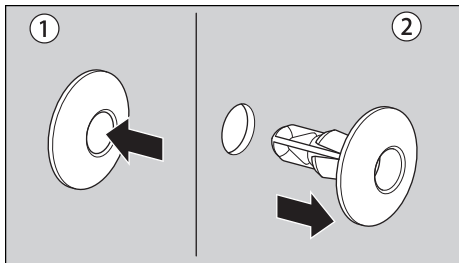

1. Press down on the centre pin to release the lock.
2. Pull the clip out of the hole.

Installation

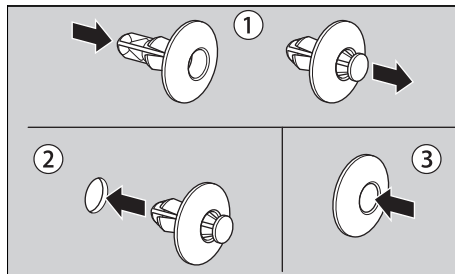

1. Push the bottom of the centre pin.
2. Insert the clip into the hole.
3. Press down on the centre pin to lock the clip.

Removing & Installing Body Components ► Front Lid

Front Lid

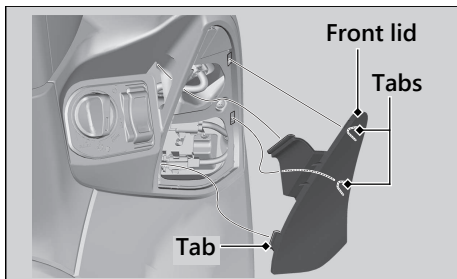
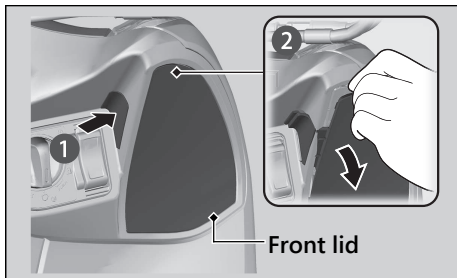

Removal

1. Push the side of the front lid.
► There is a gap at the top of the front lid.
2. Put your finger in the gap at the top of the front lid and pull out the front lid backward.

Installation

Install the front lid in the reverse order of removal.
Make sure that all tabs are installed securely in position.

Removing & Installing Body Components ► Fuel Tank Cover and Rear Centre Cover

Fuel Tank Cover and Rear Centre Cover

Maintenance

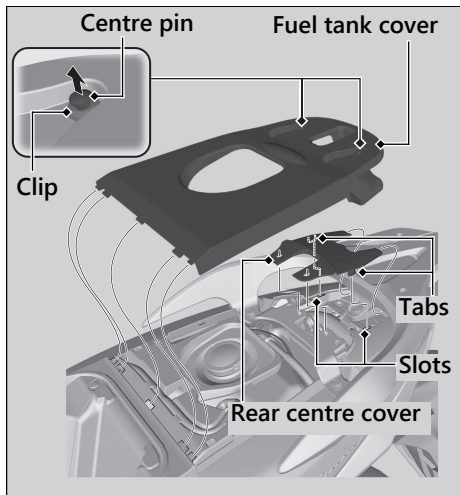

Removal

1. Open the seat. ► P. 58
2. Pull up the centre pin.
 - The clip does not come off a fuel tank cover.
3. Remove the fuel tank cover.
4. Remove the rear centre cover by releasing the tabs from their slots.

Installation

Install the parts in the reverse order of removal.

Removing & Installing Body Components ► Maintenance Lid

Maintenance Lid

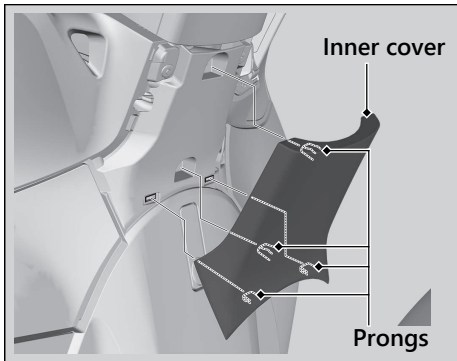

Removal

1. Remove the inner cover by releasing the prongs from their slots.

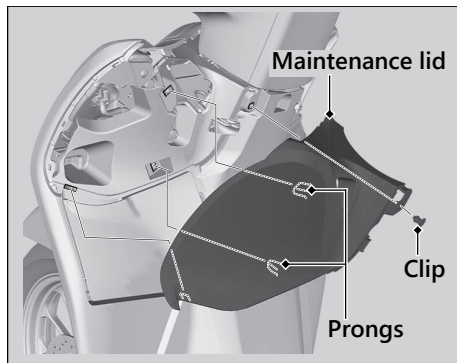

2. Remove the clip. ► P. 82
3. Remove the maintenance lid by releasing the prongs from their slots.

Installation

Install the parts in the reverse order of removal.

Engine Oil

Checking the Engine Oil

Check the engine oil with the Idling Stop switch at  (Idling).

1. If the engine is cold, idle the engine for 3 to 5 minutes.
2. Turn the ignition switch to the  (Off) position and wait for 2 to 3 minutes.
3. Place your vehicle on its centre stand on a firm, level surface.
4. Remove the oil fill cap/dipstick and wipe it clean.
5. Insert the oil fill cap/dipstick until it seats, but don't screw it in.
6. Check that the oil level is between the upper level and lower level marks on the oil fill cap/dipstick.
7. Securely install the oil fill cap/dipstick.

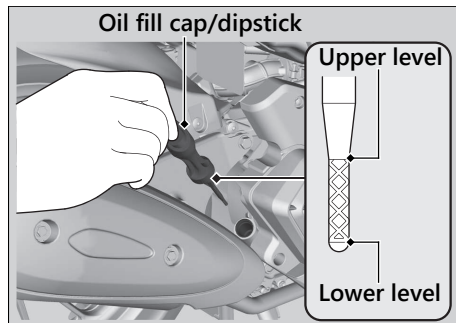

Adding Engine Oil

If the engine oil is below or near the lower level mark, add the recommended engine oil.

➤ P. 72, ➤ P. 139

1. Remove the oil fill cap/dipstick. Add the recommended oil until it reaches the upper level mark.
 - Place your vehicle on its centre stand on a firm, level surface when checking the oil level.
 - Do not overfill above the upper level mark.
 - Make sure no foreign objects enter the oil filler opening.
 - Wipe up any spills immediately.
2. Securely reinstall the oil fill cap/dipstick.

NOTICE

Overfilling with oil or operating with insufficient oil can cause damage to your engine. Do not mix different brands and grades of oil.

For the recommended oil and oil selection guidelines, see "Maintenance Fundamentals."

➤ P. 72

Coolant

Checking the Coolant

Check the coolant level in the reserve tank while the engine is cold.

1. Place your vehicle on a firm, level surface.
2. Hold your vehicle in an upright position.
3. Open the seat.  P. 58
4. Check that the coolant level is between the UPPER level and LOWER level marks on the reserve tank.

If the coolant level is dropping noticeably or the reserve tank is empty, you likely have a serious leak. Have your vehicle inspected by your dealer.

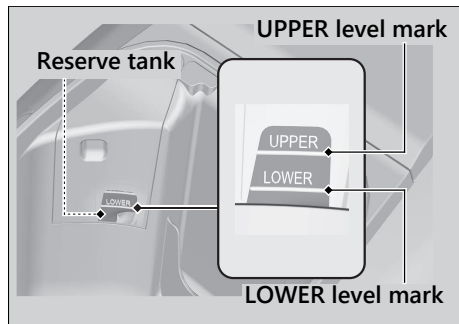

Adding Coolant

If the coolant level is below the LOWER level mark, add the recommended coolant (► P. 74) until the level reaches the UPPER level mark.

Add fluid only from the reserve tank cap and do not remove the radiator cap.

1. Remove the clip. ► P. 82
2. Remove the reserve tank lid.
3. Remove the reserve tank cap and add fluid while monitoring the coolant level.
 - Do not overfill above the UPPER level mark.
 - Make sure no foreign objects enter the reserve tank opening.
4. Securely reinstall the reserve tank cap.
5. Install the reserve tank lid and the clip.
6. Close the seat.

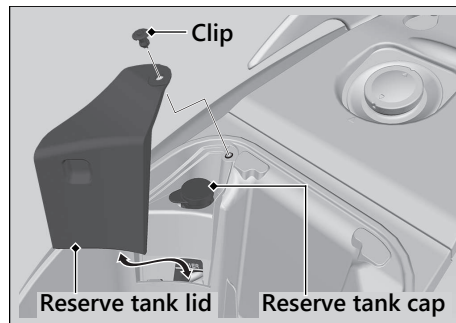

⚠ WARNING

Removing the radiator cap while the engine is hot can cause the coolant to spray out, potentially scalding you.

Always let the engine and radiator cool down before removing the radiator cap.

Brakes

Checking Brake Fluid

1. Place your vehicle in an upright position on a firm, level surface.
2. Check that the brake fluid reservoir is horizontal and that the fluid level is:
 - Front brake** above the LWR mark.
 - Combi brake** between the LOWER level and UPPER level marks.

If the brake fluid level in either reservoir is below the LWR mark or LOWER level mark or the brake lever freeplay becomes excessive, inspect the brake pads for wear.

If the brake pads are not worn, you most likely have a leak. Have your vehicle inspected by your dealer.

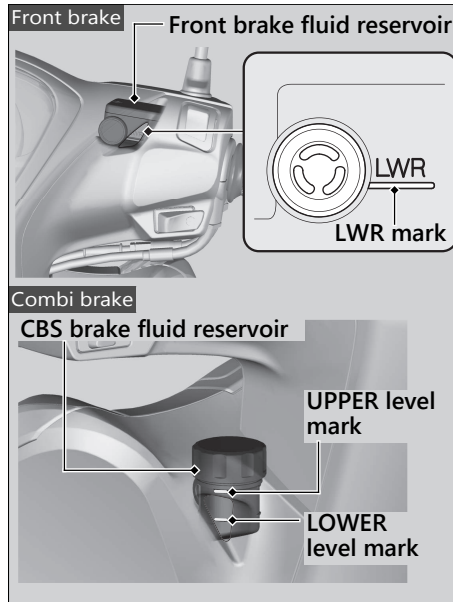

Brakes ► Inspecting the Front Brake Pads

Inspecting the Front Brake Pads

Check the condition of the brake pad wear indicators.

The pads need to be replaced if a brake pad is worn to the bottom of the indicator. Inspect the brake pads from in front of the brake caliper.

If necessary have the pads replaced by your dealer.

Always replace both left and right brake pads at the same time.

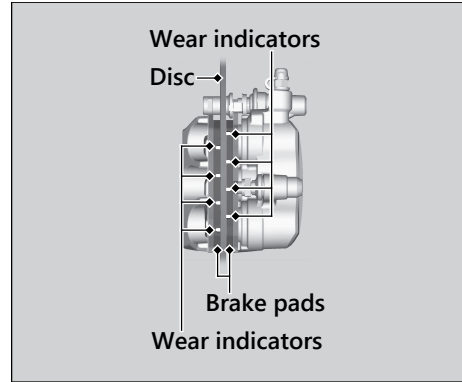

Brakes ► Inspecting the Rear Brake Lever Freeplay

Inspecting the Rear Brake Lever Freeplay

1. Place the vehicle on its centre stand.
2. Measure the distance the rear brake lever moves before the brake takes hold.

Freeplay at the tip of the brake lever:

10 - 20 mm (0.4 - 0.8 in)

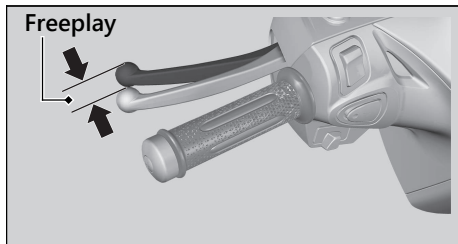

Check the brake cable for kinks or signs of wear. If necessary have it replaced by your dealer.

Lubricate the brake cable with a commercially available cable lubricant to prevent premature wear and corrosion.

Make sure the brake arm, spring and fastener are in good condition.

Adjusting the Rear Brake Lever Freeplay

Adjust the freeplay of the brake lever with the front wheel pointed straight ahead. Make sure the cut-out on the adjusting nut is seated on the brake arm pin when adjusting the freeplay.

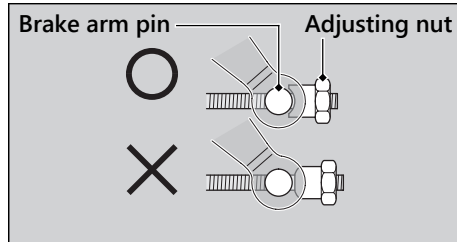

If proper adjustment cannot be obtained by this method, see your dealer.

Brakes ► Adjusting the Rear Brake Lever Freeplay

1. Adjust by turning the rear brake adjusting nut a half-turn at a time.

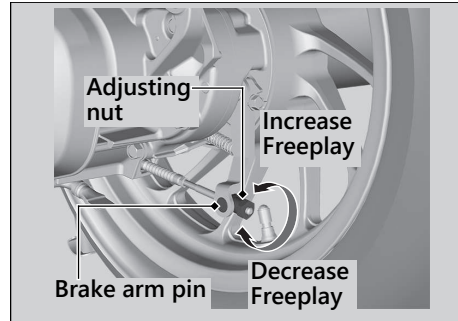

2. Apply the brake several times and check for free wheel rotation after the brake lever is released.

Brakes ► Adjusting the Rear Brake Lever Freeplay

3. Push the brake arm to confirm that there is a gap between the rear brake adjusting nut and brake arm pin.

Maintenance

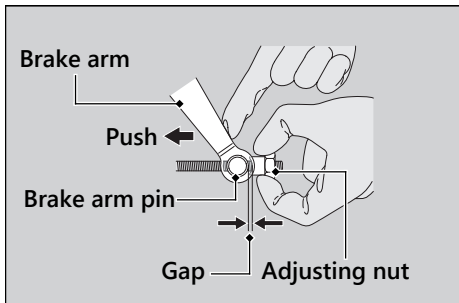

After adjustment, confirm the freeplay of the brake lever.

Make sure the brake arm, spring and fastener are in good condition.

NOTICE

Do not turn the adjuster beyond its natural limits.

Brakes ► Inspecting the Rear Brake Shoe Wear

Inspecting the Rear Brake Shoe Wear

The rear brake is equipped with a brake wear indicator.

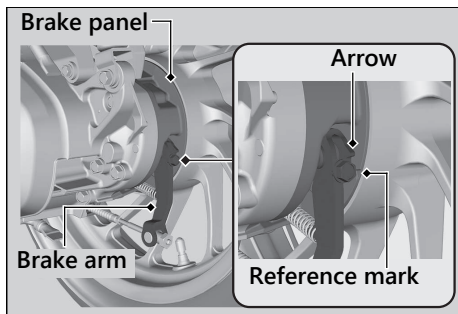

When the brake is applied, an arrow attached to the brake arm moves toward a reference mark on the brake panel. If the arrow aligns with the reference mark on full application of the brake, the brake shoes must be replaced. See your dealer for this service.

When the brake service is necessary, see your dealer. Use only Honda Genuine Parts or its equivalent.

Side Stand

Checking the Side Stand

Maintenance

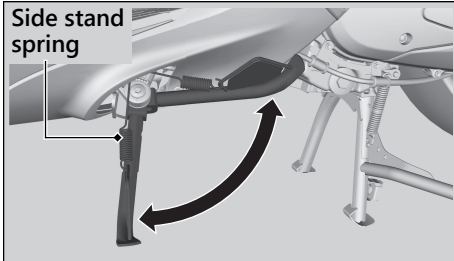

1. Place your vehicle on its centre stand on a firm, level surface.
2. Check that the side stand operates smoothly. If the side stand is stiff or squeaky, clean the pivot area and lubricate the pivot bolt with clean grease.
3. Check the spring for damage or loss of tension.
4. Sit on the vehicle and raise the side stand.
5. Start the engine.
6. Lower the side stand all the way. The engine should stop as you lower the side stand. If the engine doesn't stop, have your vehicle inspected by your dealer.

Throttle

Checking the Throttle

With the engine off, check that the throttle rotates smoothly from fully closed to fully open in all steering positions and throttle freeplay is correct. If the throttle does not move smoothly, close automatically, or if the cable is damaged, have the vehicle inspected by your dealer.

Freeplay at the throttle grip flange:

2 - 6 mm (0.1 - 0.2 in)

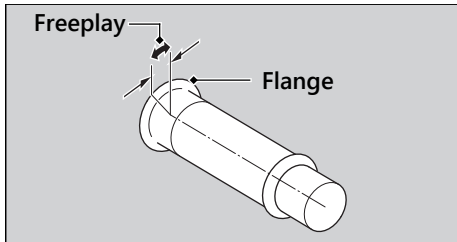

Other Adjustments

Adjusting the Rear Suspension

I Spring Preload

You can adjust the spring preload by the adjuster to suit the load or the road surface. Use the pin spanner and the extension bar to turn the adjuster. Turn the position 2 to 5 increase spring preload (hard). The standard position is 1.

Maintenance

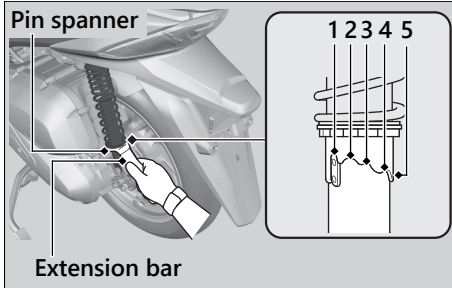

NOTICE

Do not turn the adjuster beyond its limits.

Other Replacement

Replacing the Honda SMART Key Battery

If the Honda SMART Key indicator flashes 5 times when the ignition switch is turned to the **I** (On) position, or the operating range becomes unstable, replace the battery as soon as possible.

We recommend to see your dealer for this service.

Battery type: CR2032

1. Remove the upper case by inserting a coin or a flat head screwdriver covered with a protective cloth into the slit.
 - ▶ Wrap a coin or a screwdriver with a protective cloth to prevent scratching the Honda SMART Key.
 - ▶ Do not touch the circuit or terminal. This may cause problems.
 - ▶ Be careful to avoid scratching the waterproof covering or allowing dust to enter.
 - ▶ Do not forcibly dismantle the Honda SMART Key body.

Other Replacement ► Replacing the Honda SMART Key Battery

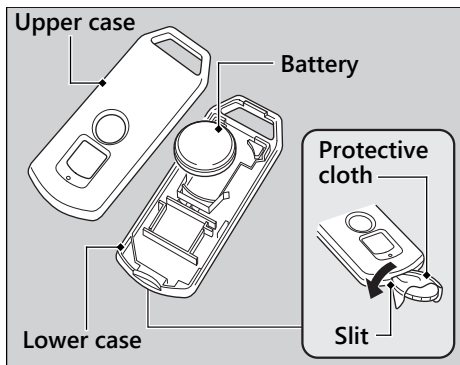

2. Replace the old battery with a new battery with the negative \ominus side facing up.
3. Snap the two halves of the remote transmitter back together.
 - Make sure that upper and lower cases are set in the right position.

⚠ WARNING

Chemical Burn Hazard: do not swallow battery.

If swallowed, the battery can cause severe internal burns and even death.

- Keep battery away from children and battery compartment securely closed.
- If the battery compartment does not close securely, stop using the product and keep it away from children.
- Immediately seek medical attention if a child may have swallowed battery.

Troubleshooting

Engine Will Not Start P. 102	Engine Does Not Start Even If the Throttle is Opened P. 109
Overheating (High coolant temperature indicator is on) P. 103	When the Honda SMART Key System Does Not Operate Properly P. 110
Warning Indicators On or Flashing P. 104	Unlock the Seat in an Emergency P. 112
PGM-FI (Programmed Fuel Injection)	Unlock the Ignition Switch in an Emergency P. 113
Malfunction Indicator Lamp (MIL)..... P. 104	Tyre Puncture P. 116
Honda SMART Key Indicator P. 105	Electrical Trouble P. 117
Other Warning Indications P. 106	Battery Goes Dead..... P. 117
Fuel Gauge Failure Indication..... P. 106	Burned-out Light Bulb P. 117
When the Idling Stop System Does Not Operate Properly P. 107	Blown Fuse..... P. 122
Idling Stop Indicator Does Not Come On .. P. 107	Unstable Engine Operation Occurs Intermittently P. 123
Engine is Not Stopped by the Idling Stop System	
While the Idling Stop Indicator is On..... P. 108	

Engine Will Not Start

Starter Motor Operates But Engine Does Not Start

Check the following items:

- Check the correct engine starting sequence. ➤ P. 48
- Check that there is petrol in the fuel tank.
- Check if the PGM-FI malfunction indicator lamp (MIL) is on.
 - ▶ If the indicator lamp is on, contact your dealer as soon as possible.

Starter Motor Does Not Operate

Check the following items:

- Check the correct engine starting sequence. ➤ P. 48
- Check for a blown fuse. ➤ P. 122
- Check for a loose battery connection (➤ P. 79) or battery terminal corrosion (➤ P. 70).
- Check the condition of the battery.
 - P. 117

If the problem continues, have your vehicle inspected by your dealer.

Overheating (High coolant temperature indicator is on)

The engine is overheating when the following occurs:

- High coolant temperature indicator comes on.
- Acceleration becomes sluggish.

If this occurs, pull safely to the side of the road and perform the following procedure. Extended fast idling may cause the high coolant temperature indicator to come on.

NOTICE

Continuing to ride with an overheated engine can cause serious damage to the engine.

1. Stop the engine using the ignition switch.
2. Allow the engine to cool with the ignition switch in the  (Off) position.
3. After the engine has cooled, inspect the radiator hose and check if there is a leak.
➡ P. 88
If there is a leak:
Do not start the engine. Transport your vehicle to your dealer.
4. Check the coolant level in the reserve tank. ➡ P. 88
▶ Add coolant as necessary.
5. If 1-4 check normal, you may continue riding, but closely monitor the high coolant temperature indicator.

Warning Indicators On or Flashing

PGM-FI (Programmed Fuel Injection) Malfunction Indicator Lamp (MIL)

If the indicator comes on while riding, you may have a serious problem with the PGM-FI system. Reduce speed and have your vehicle inspected by your dealer as soon as possible.

Troubleshooting

Warning Indicators On or Flashing ► Honda SMART Key Indicator

Honda SMART Key Indicator

When the Honda SMART Key indicator flashes 5 times



Replacing the Honda SMART Key Battery  P. 99

When the Honda SMART Key indicator is flashing while the ignition switch is in the (On) position

The Honda SMART Key indicator flashes when communication between your vehicle and Honda SMART Key stops after turning the ignition switch to the (On) position. It is probably caused by the following:

- Strong radio waves or noise are affecting the system
- You lose the Honda SMART Key while riding

However, this does not affect the operation of your vehicle until stop the engine except the idling stop.

If you turn the ignition switch to the SEAT,  (Off) or  (Lock) position while the Honda SMART Key indicator is flashing, the ignition switch ring, turn signals and the Honda SMART Key indicator will come on for about 20 seconds, automatically go off, and then the ignition switch will lock.

► Turn signals blink at the beginning and end of this function.

To stop this flashing and ringing, press and hold the ignition switch for more than 2 seconds. After the flashing and ringing stop, the ignition switch is locked.

If you do not have the Honda SMART Key, the ignition switch can be unlocked in another way.  P. 113

Other Warning Indications

Fuel Gauge Failure Indication

If the fuel system has an error, the fuel gauge indicators will be displayed as shown in the illustration.

If this occurs, see your dealer as soon as possible.

Troubleshooting

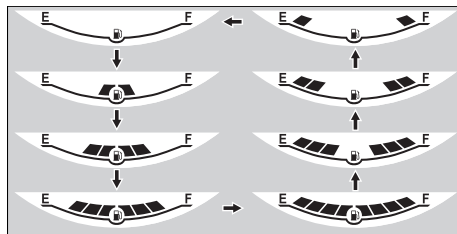
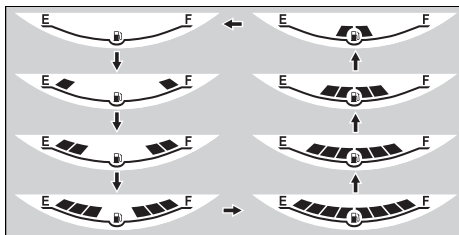

When the Idling Stop System Does Not Operate Properly

Idling Stop Indicator Does Not Come On

When the Idling Stop indicator does not come on, perform the followings.

If the Idling Stop switch is at  (Idling):

Press the Idling Stop switch to  (Idling Stop).

If the engine is cold:

Warm up the engine.

The Idling Stop system does not operate when the engine is cold.

If you did not ride the vehicle after engine starts:

Ride the vehicle at speeds of over 10 km/h (6 mph). The Idling Stop system does not operate until you ride once.

If PGM-FI malfunction indicator lamp (MIL) lights:

When the PGM-FI malfunction indicator lamp (MIL) lights, the Idling Stop system does not operate for protection of the engine. See your dealer.

If the battery voltage is low:

Ride the vehicle awhile, then stop the engine and then restart the engine with start button referring to the starting procedure (▶ P. 48) for standard engine starting. The Idling Stop system may not operate if the battery voltage is low.

If this occurs frequently, contact your dealer.

When the Idling Stop System Does Not Operate Properly ▶ Engine is Not Stopped by the Idling Stop System While the Idling Stop Indicator is On

Engine is Not Stopped by the Idling Stop System While the Idling Stop Indicator is On

Troubleshooting

When the engine is not stopped by the Idling Stop system while the Idling Stop indicator is on, perform the followings.

If the vehicle does not stop completely:

Stop the vehicle completely. The Idling Stop system operates if the speed is only at 0 km/h (0 mph).

If the throttle is not closed completely:

Close the throttle completely.

When the Idling Stop System Does Not Operate Properly ► Engine Does Not Start Even If the Throttle is Opened

Engine Does Not Start Even If the Throttle is Opened

Engine does not start even if the throttle is opened, perform the followings.

If the side stand is down:

When you put down the side stand, Idling Stop system will be cancelled. At the same time, the flashing Idling Stop indicator changes to stay on. See starting procedure (▶ P. 48) for standard engine starting.

If the Idling Stop switch is at (Idling):

While the engine is stopping by the Idling Stop system, if you press the Idling Stop switch to  (Idling), the Idling Stop system will be cancelled. Restart the engine with the start button referring to the starting

procedure (▶ P. 48) for standard engine starting.

If the Idling Stop indicator flashes (the Idling Stop switch is at  (Idling Stop) position), but engine does not start even if the throttle is opened, perform the followings.

Low (or dead) battery or battery lead is loose:

Check the battery and battery terminals. If the battery is weak, contact your dealer.

When the Honda SMART Key System Does Not Operate Properly

When the Honda SMART Key system does not work properly, perform the following.

- Check that the Honda SMART Key system is activated.

Lightly push the ON/OFF button.

If the Honda SMART Key LED is red, activate the Honda SMART Key system.

▶ P. 36

If the Honda SMART Key LED does not respond, replace the battery.

- Check that there is no communication failure in the Honda SMART Key system. The Honda SMART Key system uses low-intensity radio waves. The Honda SMART Key system may not work properly in the following conditions:

- ▶ When there are facilities nearby that generate strong radio waves or noise such as TV towers, power stations, radio stations, or airports.
- ▶ When you carry the Honda SMART Key with a laptop or wireless communication device such as a radio or mobile phone.
- ▶ When the Honda SMART Key comes into contact with or is covered by metal objects.

When the Honda SMART Key System Does Not Operate Properly

- Check that a registered Honda SMART Key is used.
Use a registered Honda SMART Key.
The Honda SMART Key system cannot be activated without a registered Honda SMART Key.
- Make sure that you do not use a broken Honda SMART Key.
If you use a broken Honda SMART Key, the Honda SMART Key system cannot be activated. Bring the emergency key and ID tag to your dealer.

- Check the battery condition and battery lead in your vehicle.
Check the battery and battery terminals. If the battery is weak, contact your dealer.

If the Honda SMART Key system cannot be activated due to other causes, contact your dealer.

Unlock the Seat in an Emergency

The seat lock can be unlocked by using the emergency key.

Open

1. Remove the front lid.  P. 83
2. Align the projection of the emergency key with the slot of the emergency seat opener, and turn the emergency key counterclockwise.
3. Open the seat and turn the emergency key clockwise

Close

1. Close and push down on the rear of the seat until it locks. Make sure that the seat is locked securely by pulling it up lightly. If the seat is not locked, turn the emergency key clockwise to lock the seat catch.
2. Install the front lid.

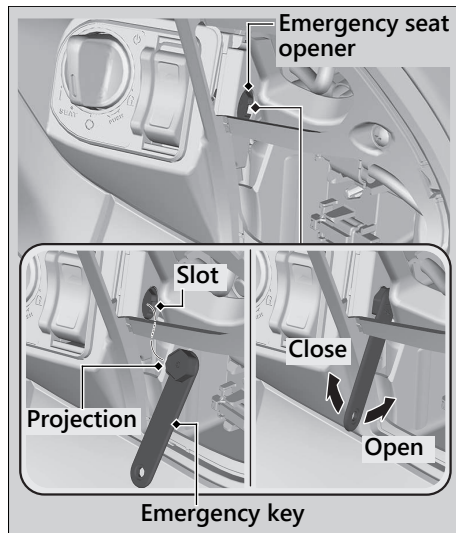

Unlock the Ignition Switch in an Emergency

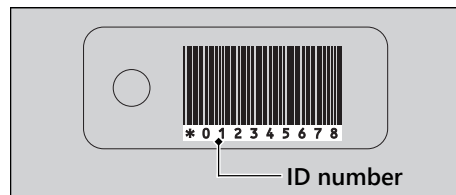
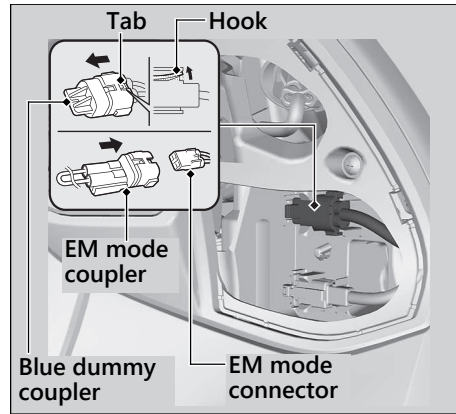

Set up to ID number input mode

1. Remove the front lid.  P. 83
2. Pull out the EM mode connector.
3. Remove the blue dummy coupler by releasing the tab of the EM mode connector while lifting the hook of the blue dummy coupler.
4. Check the ID number on the ID tag.
5. Connect the EM mode coupler provided in the tool kit to the EM mode connector.



Unlock the Ignition Switch in an Emergency

ID number input

You can input your ID number by pressing the ignition switch when the ignition switch is  (Off),  (Lock) and SEAT position. Input the ID number on the ID tag in order from the left in turn by pressing the ignition switch.

The ID number is authenticated according to the number of times the ignition switch is pushed.

Push the ignition switch the desired number of times within 5 seconds when the ignition switch ring comes on. After 5 seconds, the ignition switch ring goes off and comes on again. This means that the inputted number is fixed, and you can input the next number.

- ▶ If the ignition switch ring does not come on in blue, the battery may be low. Contact your dealer.

Example:

- To input "0", wait for 5 seconds without pushing the ignition switch when the ignition switch ring comes on.
- To input "1", push the ignition switch once within 5 seconds when the ignition switch ring comes on.

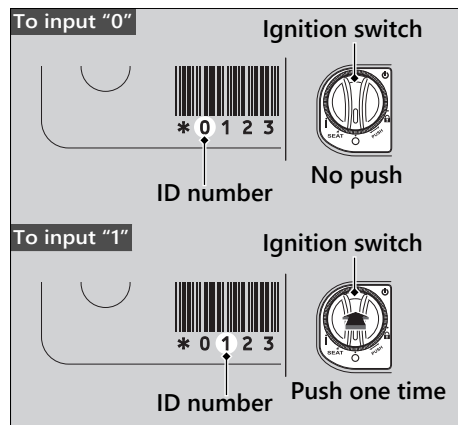

ID number input success

After the last ID number is inputted, through, the ignition switch ring and Honda SMART Key Indicator will flash every 2 seconds until the EM mode coupler is removed.

Be sure to remove the EM mode coupler and return the blue dummy coupler. The ignition switch is then unlocked. Reinstall the parts in reverse order of removal and turn the ignition switch to the **I** (On) position within 6 minutes. You can start the engine.

To lock the ignition switch, turn the ignition switch to the SEAT, **O** (Off), or **L** (Lock) position, and press and hold the ignition switch for 2 seconds. The ignition switch also locks automatically when the ignition switch has been in the SEAT, **O** (Off), or **L** (Lock) position for about 6 minutes after the ID number is successfully inputted.

When the ignition switch is locked, the ignition switch ring goes off.

To unlock the ignition switch again, repeat the procedure for unlocking the ignition switch.

Unlock the Ignition Switch in an Emergency**ID number input failure**

After the last ID number is inputted, the ignition switch ring and Honda SMART Key Indicator will flash every second until the EM mode coupler is removed, and the ignition switch cannot be unlocked.

Pull out the EM mode coupler and reconnect it to the EM mode connector. Follow the procedure again. ➤ P. 114

ID number input cancel

Pull out the EM mode coupler from the EM mode connector.

Also, if you make a mistake while inputting the ID number, remove the EM mode coupler from the EM mode connector, connect it to the EM mode connector again, and then re-input the ID number from the beginning.

- Store the removed EM mode coupler in the tool kit at all times.

Tyre Puncture

Repairing a puncture or removing a wheel requires special tools and technical expertise. We recommend you have this type of service performed by your dealer. After an emergency repair, always have the tyre inspected/replaced by your dealer.

Troubleshooting

Emergency Repair Using a Tyre Repair Kit

If your tyre has a minor puncture, you can make an emergency repair using a tubeless tyre repair kit.

Follow the instructions provided with the emergency tyre repair kit.

Riding your vehicle with a temporary tyre repair is very risky. Do not exceed 50 km/h (30 mph). Have the tyre replaced by your dealer as soon as possible.

⚠️WARNING

Riding your vehicle with a temporary tyre repair can be risky. If the temporary repair fails, you can crash and be seriously injured or killed.

If you must ride with a temporary tyre repair, ride slowly and carefully and do not exceed 50 km/h (30 mph) until the tyre is replaced.

Electrical Trouble

Battery Goes Dead

Charge the battery using a motorcycle battery charger.

Remove the battery from the vehicle before charging.



Do not use an automobile-type battery charger, as these can overheat a motorcycle battery and cause permanent damage. If the battery does not recover after recharging, contact your dealer.

NOTICE

Jump starting using an automobile battery can damage your vehicle's electrical system and is not recommended.

Burned-out Light Bulb

Follow the procedure below to replace a burned-out light bulb.

Turn the ignition switch to the  (Off) or  (Lock) position.

Allow the bulb to cool before replacing it.

Do not use bulbs other than those specified.

Check the replacement bulb for correct operation before riding.

For the light bulb wattage, see "Specifications." ➤ P. 140

The headlight and position light use several LEDs. If there is an LED which is not turned on, see your dealer for servicing.

Electrical Trouble ► Burned-out Light Bulb

Brakelight/Tailight and Rear Turn Signal Bulb

Troubleshooting

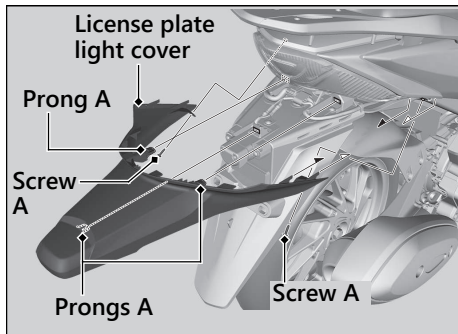

1. Remove the license plate light cover by removing the screws A and the prongs.
2. Remove the fuel tank cover and the rear centre cover. ► P. 84

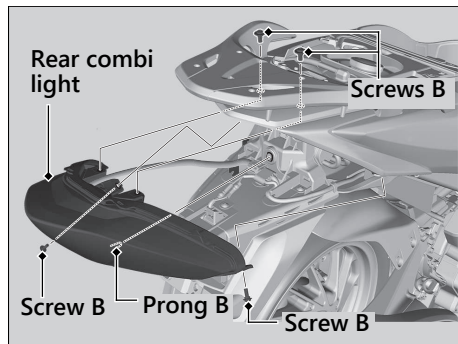

3. Remove the rear combi light by removing the screws B and the prong B.

Electrical Trouble ► Burned-out Light Bulb

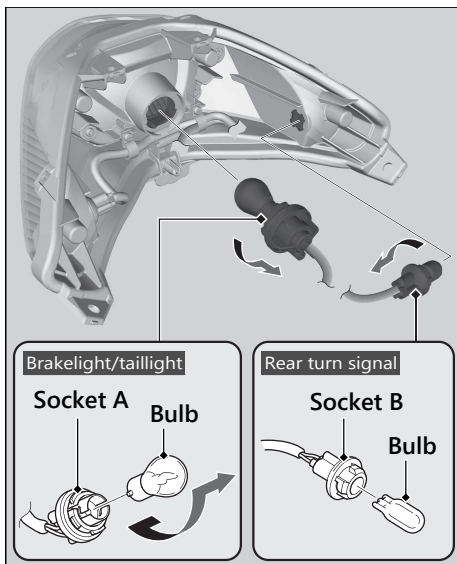
**Brakelight/Taillight Bulb**

4. Turn the socket A counterclockwise and pull it out.
5. Slightly press the bulb in and turn it counterclockwise.
6. Install a new bulb and parts in the reverse order of removal.

Rear Turn Signal Bulb

4. Turn the socket B counterclockwise and pull it out.
5. Pull out the bulb without turning it.
6. Install a new bulb and parts in the reverse order of removal.
 - Use only the amber bulb.

Electrical Trouble ▶ Burned-out Light Bulb

Front Turn Signal Bulb

Troubleshooting

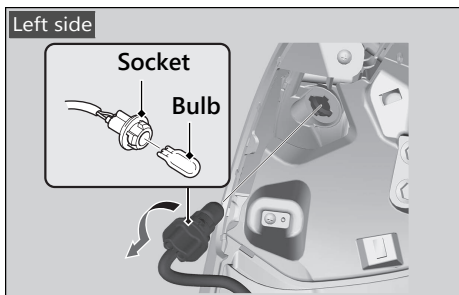
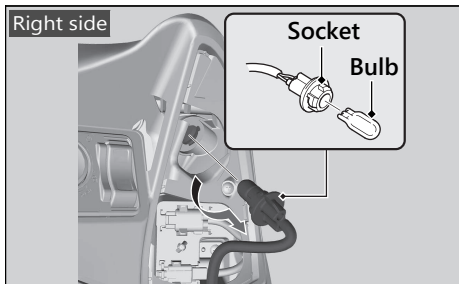

1. **When remove the right turn signal bulb**
Remove the front lid. ▶ P. 83
When remove the left turn signal bulb
Remove the maintenance lid. ▶ P. 85
2. Turn the socket counterclockwise and pull it out.
3. Pull out the bulb without turning it.
4. Install a new bulb and parts in the reverse order of removal.
▶ Use only the amber bulb.

Electrical Trouble ▶ Burned-out Light Bulb

License Plate Light Bulb

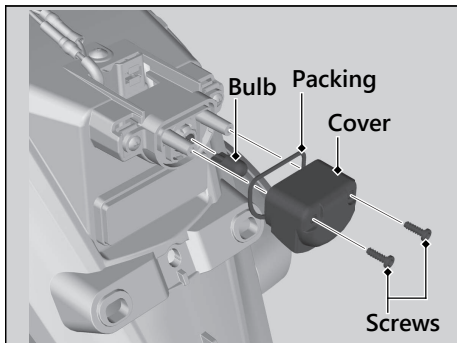

1. Remove the license plate light cover.
▶ P. 118
2. Remove the cover by removing the screws.
3. Pull out the bulb without turning it.
4. Install a new bulb and parts in the reverse order of removal.
▶ After putting back the packing in place, install the license plate light cover.

Electrical Trouble ► Blown Fuse

Blown Fuse

Before handling fuses, see “Inspecting and Replacing Fuses.” ► P. 72

I Fuse Box Fuses

Troubleshooting

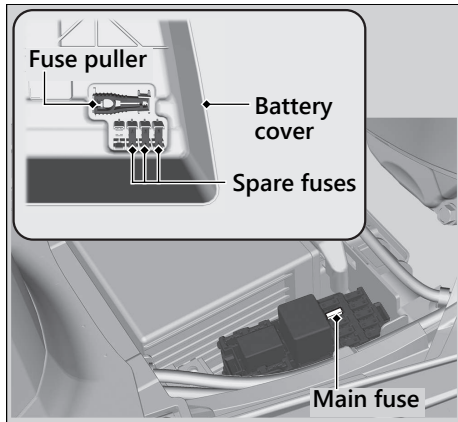

1. Remove the battery cover. ► P. 80
2. Pull the main fuse and other fuses out one by one with the fuse puller furnished in reverse side of the battery cover and check for a blown fuse. Always replace a blown fuse with a spare fuse of the same rating.
 - Spare fuses are provided on reverse side of the battery cover.
3. Install the parts in the reverse order of removal.

NOTICE

If a fuse fails repeatedly, you likely have an electrical problem. Have your vehicle inspected by your dealer.

Unstable Engine Operation Occurs Intermittently

If the fuel pump filter is clogged, unstable engine operation will occur intermittently while riding.

Even if this symptom occurs, you can continue to ride your vehicle.

If unstable engine operation occurs even if sufficient fuel is available, have your vehicle inspected by your dealer as soon as possible.

Information

Service Diagnostic Recorders.....	P. 125
Keys.....	P. 125
Instruments, Controls, & Other Features...	P. 129
Caring for Your Vehicle.....	P. 129
Storing Your Vehicle.....	P. 132
Transporting Your Vehicle	P. 133
You & the Environment	P. 134
Serial Numbers	P. 135
Fuels Containing Alcohol	P. 136
Catalytic Converter	P. 137

Service Diagnostic Recorders



Your vehicle is equipped with service-related devices that record information about powertrain performance and riding conditions. The data can be used to help technicians diagnose, repair and maintain the vehicle. This data may not be accessed by anyone else except as legally required or with the permission of the vehicle owner.

However this data may be accessed by Honda, its authorised dealers and authorised repairers, employees, representatives and contractors only for the purpose of the technical diagnosis, research and development of the vehicle.

Keys

Emergency Key

The emergency key is used for an emergency.

- To unlock the seat.  P. 112
- To unlock the ignition switch.  P. 113

Do not store the emergency key in any compartment.

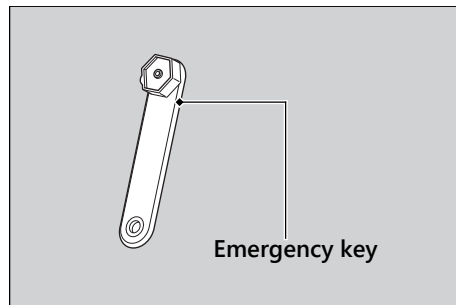

Keys

Honda SMART Key

Carrying the Honda SMART Key allows you to perform the following operations:

- Locking or unlocking the ignition switch
- Releasing the seat lock
- Locking or unlocking the steering

The ID number of the Honda SMART Key is on the ID tag. You can also unlock the ignition switch by inputting the ID number.

Always carry both the emergency key and ID tag, but separate from the Honda SMART Key, to avoid losing all of them at the same time.

Also store a copy of your ID number in a safe place other than your vehicle.

The Honda SMART Key contains electronic circuits. If the circuits are damaged, the Honda SMART Key will not allow you to perform any operations.

- Do not drop the Honda SMART Key or set heavy objects on them.
- Protect the Honda SMART Key from direct sunlight, high temperature, and high humidity.
- Do not scratch or puncture.
- Do not store near any magnetized products such as a magnetized key chain.
- Always keep the Honda SMART Key away from electric appliances such as a TV, radio, PC or low-frequency massage device.

Keys

- Keep the Honda SMART Key away from liquids. If it gets wet, dry it immediately with a soft cloth.
- Keep the Honda SMART Key away from the vehicle while washing the vehicle.
- Do not burn.
- Do not wash in an ultrasonic cleaner.
- If fuel, wax, or grease adhere to the Honda SMART Key, wipe it off immediately to avoid cracking or warping.
- Do not disassemble the Honda SMART Key other than when changing a battery. Only the cover of the Honda SMART Key can be disassembled. Do not disassemble other parts.
- Do not lose your Honda SMART Key. If you lose it, you will need to register a new Honda SMART Key. See your dealer with your emergency key and ID tag for registration.

The battery in the Honda SMART Key system normally lasts about 2 years.

Do not keep mobile phones or other radio transmitting devices in any compartment. The radio frequency from the devices will interrupt the Honda SMART Key system.

To get an additional Honda SMART Key, take the Honda SMART Key and the vehicle to your dealer.

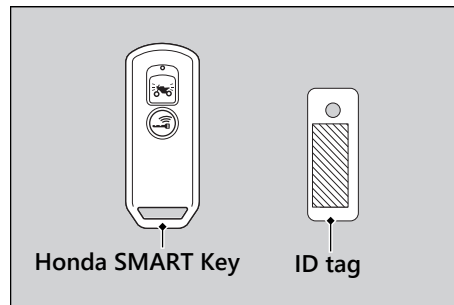

Information

Keys

EU Directive

This Honda SMART Key system complies with the RE (Radio Equipment) Directive (2014/53/EU).



The declaration of conformity to RE Directive is provided to the owner at the time of purchase. The declaration of conformity should be kept at a safe place. When the declaration of conformity is lost or is not provided, contact your dealer.

Information

South Africa only



Singapore only



Morocco only



Instruments, Controls, & Other Features

Ignition Switch

Leaving the ignition switch in the **I** (On) position with the engine stopped will drain the battery.

Do not turn the ignition switch while riding.

Odometer

The display locks at 999,999 when the read-out exceeds 999,999.

Tripmeter

The tripmeters return to 0.0 when each read-out exceeds 9,999.9.

Document Bag

The owner's manual, registration, and insurance information can be stored in the plastic document bag located under the seat.

Instruments, Controls, & Other Features

Caring for Your Vehicle

Frequent cleaning and polishing is important to ensure the life of your Honda. A clean vehicle makes it easier to spot potential problems. In particular, seawater and salts used to prevent ice on roads promote the formation of corrosion. Always wash your vehicle thoroughly after riding on coastal or treated roads.

Washing

Allow the engine, muffler, brakes, and other high-temperature parts to cool before washing.

1. Rinse your vehicle thoroughly using a low pressure garden hose to remove loose dirt.
2. If necessary, use a sponge or a soft towel with mild cleaner to remove road grime.
 - ▶ Clean the headlight lens, panels, and other plastic components with extra care to avoid scratching them. Avoid directing water into the air cleaner, muffler, and electrical parts.

Caring for Your Vehicle

3. Thoroughly rinse your vehicle with plenty of clean water and dry with a soft, clean cloth.
4. After the vehicle dries, lubricate any moving parts.
 - ▶ Make sure that no lubricant spills onto the brakes or tyres. Brake discs, pads, drum or shoes contaminated with oil will suffer greatly reduced braking effectiveness and can lead to a crash.
5. Apply a coat of wax to prevent corrosion.
 - ▶ Avoid products that contain harsh detergents or chemical solvents. These can damage the metal, paint, and plastic on your vehicle.
Keep the wax clear of the tyres and brakes.
 - ▶ If your vehicle has any mat painted parts, do not apply a coat of wax to the mat painted surface.

Information

Washing Precautions

Follow these guidelines when washing:

- Do not use high-pressure washers:
 - ▶ High-pressure water cleaners can damage moving parts and electrical parts, rendering them inoperable.
 - ▶ Water in the air intake can be drawn into the throttle body and/or enter the air cleaner.
- Do not direct water at the muffler:
 - ▶ Water in the muffler can prevent starting and causes rust in the muffler.
- Dry the brakes:
 - ▶ Water adversely affects braking effectiveness. After washing, apply the brakes intermittently at low speed to help dry them.
- Do not direct water under the seat:
 - ▶ Water in the under seat compartment can damage your documents and other belongings.

Caring for Your Vehicle

- Do not direct water at the air cleaner:
 - ▶ Water in the air cleaner can prevent the engine from starting.
- Do not direct water near the headlight:
 - ▶ The headlight's inside lens may fog temporarily after washing or while riding in the rain. This does not impact the headlight function.
However, if you see a large amount of water or ice accumulated inside the lens(es), have your vehicle inspected by your dealer.
- Do not use wax or polishing compounds on mat painted surface:
 - ▶ Use a soft cloth or sponge, plenty of water, and a mild detergent to clean mat painted surfaces. Dry with a soft clean cloth.

Aluminium Components

Aluminium will corrode from contact with dirt, mud, or road salt. Clean aluminium parts regularly and follow these guidelines to avoid scratches:

- Do not use stiff brushes, steel wool, or cleaners containing abrasives.
- Avoid riding over or scraping against curbs.

Information

Storing Your Vehicle

Panels

Follow these guidelines to prevent scratches and blemishes:

- Wash gently using a soft sponge and plenty of water.
- To remove stubborn stains, use diluted detergent and rinse thoroughly with plenty of water.
- Avoid getting petrol, brake fluid, or detergents on the instruments, panels, or headlight.

Exhaust Pipe and Muffler

When the exhaust pipe and muffler are painted, do not use a commercially available abrasive kitchen cleaning compound. Use a neutral detergent to clean the painted surface on the exhaust pipe and muffler. If you are not sure if your exhaust pipe and muffler are painted, contact your dealer.

Storing Your Vehicle

If you store your vehicle outdoors, you should consider using a full-body cover.

If you won't be riding for an extended period, follow these guidelines:

- Wash your vehicle and wax all painted surfaces (except mat painted surfaces). Coat chrome pieces with rust-inhibiting oil.
- Place your vehicle on its centre stand and position a block so that both tyres are off the ground.
- After rain, remove the body cover and allow the vehicle to dry.
- Remove the battery (📄 P. 79) to prevent discharge. Fully charge the battery and then place it in a shaded, well-ventilated area.
 - ▶ If you leave the battery in place, disconnect the negative ⊖ terminal to prevent discharge.

After removing your vehicle from storage, inspect all maintenance items required by the Maintenance Schedule.

Transporting Your Vehicle

Transporting Your Vehicle

If your vehicle needs to be transported, it should be carried on a motorcycle trailer or a flatbed truck or trailer that has a loading ramp or lifting platform, and motorcycle tie-down straps. Never try to tow your vehicle with a wheel or wheels on the ground.

NOTICE

Towing your vehicle with a wheel or wheels on the ground can cause serious damage to the transmission.

You & the Environment

You & the Environment

Owning and riding a vehicle can be enjoyable, but you must do your part to protect the environment.

Choose Sensible Cleaners

Use a biodegradable detergent when you wash your vehicle. Avoid aerosol spray cleaners that contain chlorofluorocarbons (CFCs) which damage the atmosphere's protective ozone layer.

Information

Recycle Wastes

Put oil and other toxic wastes in approved containers and take them to a recycling centre. Call your local or state office of public works or environmental services to find a recycling centre in your area, and to get instructions on how to dispose of non-recyclable wastes. Do not place used engine oil in the trash, or pour it down a drain or on the ground. Used oil, petrol, coolant, and cleaning solvents contain poisons that can hurt refuse workers and contaminate drinking water, lakes, rivers, and oceans.

Serial Numbers

Serial Numbers

The frame and engine serial numbers uniquely identify your vehicle and are required in order to register your vehicle. They may also be required when ordering replacement parts.

To check the frame number, remove the fuel tank cover and rear centre cover. ➤ P. 84

You should record these numbers and keep them in a safe place.

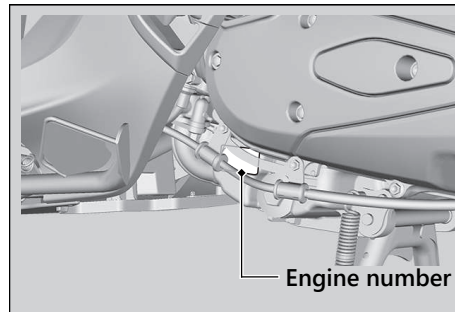
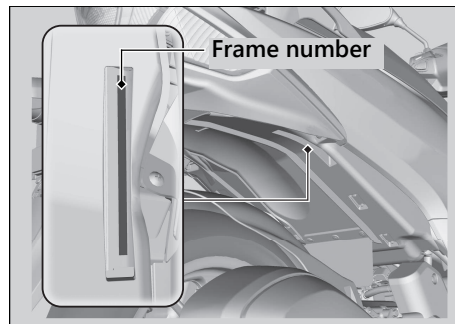

Information

Fuels Containing Alcohol

Fuels Containing Alcohol

Some conventional fuels blended with alcohol are available in some locales to help reduce emissions to meet clean air standards. If you plan to use blended fuel, check that it is unleaded and meets the minimum octane rating requirement.

The following fuel blends can be used in your vehicle:

- Ethanol (ethyl alcohol) up to 10% by volume.
 - ▶ Petrol containing ethanol may be marketed under the name Gasohol.

The use of petrol containing more than 10% ethanol may:

- Damage the painting of the fuel tank.
- Damage the rubber tubes of the fuel line.
- Cause corrosion of the fuel tank.
- Cause poor drivability.

NOTICE

Use of blended fuels containing higher than approved percentages can damage metal, rubber, plastic parts of your fuel system.

If you notice any undesirable operating symptoms or performance problems, try a different brand of petrol.

Catalytic Converter

Catalytic Converter

This vehicle is equipped with a three-way catalytic converter. The catalytic converter contains precious metals that serve as catalysts in high temperature chemical reactions that convert hydrocarbons (HC), carbon monoxide (CO), and oxides of nitrogen (NOx) in the exhaust gasses into safe compounds.

A defective catalytic converter contributes to air pollution and can impair your engine's performance. A replacement unit must be an original Honda part or equivalent.

Follow these guidelines to protect your vehicle's catalytic converter.

- Always use unleaded petrol. Leaded petrol will damage the catalytic converter.
- Keep the engine in good running condition.
- Have your vehicle serviced if your engine is misfiring, backfiring, stalling, or otherwise not running properly, stop riding and turn off the engine.

Specifications

■ Main Components

Overall length	1,950 mm (76.8 in)	
Overall width	670 mm (26.4 in)	
Overall height	1,100 mm (43.3 in)	
Wheelbase	1,305 mm (51.4 in)	
Minimum ground clearance	150 mm (5.9 in)	
Caster angle	26° 30'	
Trail	70 mm (2.8 in)	
Curb weight	118 kg (260 lb)	
Maximum weight capacity *1	177 kg (390 lb)	
	15.5 kg (34 lb)	
Maximum luggage weight *2	Glove box	1.0 kg (2.2 lb)
	Shopping hook	1.5 kg (3.3 lb)
	Centre compartment	10 kg (22 lb)
	Rear carrier	3 kg (6.6 lb)
Passenger capacity	Rider and 1 passenger	
Minimum turning radius	1.90 m (6.2 ft)	

*1 : Including rider, passenger, all luggage, and accessories

*2 : Includes the weight of the luggage and added accessories

Displacement	125 cm ³ (7.6 cu-in)
Bore x stroke	52.5 x 55.5 mm (2.07 x 2.19 in)
Compression ratio	11.5:1
Fuel	Unleaded petrol Recommended: 95 RON or higher
Fuel containing alcohol	ETHANOL up to 10 % by volume
Tank capacity	5.6 L (1.48 US gal, 1.23 Imp gal)
Battery	YTZ8V
	12 V-7.0 Ah (10 HR) / 7.4 Ah (20 HR)
Primary reduction	V-Matic (2.65:1-0.82:1)
Final reduction	11.271

Specifications

■ Service Data

Tyre size	Front	80/90-16M/C 43P
	Rear	100/90-14M/C 57P
Tyre type		Bias-ply, tubeless
Recommended tyre	Front	CHENG SHIN C-922F
	Rear	CHENG SHIN C-922R
Tyre category of use	Normal	Permitted
	Special	Not permitted
	Snow	Not permitted
	Moped	Not permitted
Tyre air pressure (Driver only)	Front	175 kPa (1.75 kgf/cm ² , 25 psi)
	Rear	200 kPa (2.00 kgf/cm ² , 29 psi)
Tyre air pressure (Driver and passenger)	Front	175 kPa (1.75 kgf/cm ² , 25 psi)
	Rear	250 kPa (2.50 kgf/cm ² , 36 psi)
Spark plug	(standard)	LMAR8L-9 (NGK)
Spark plug gap		0.80 - 0.90 mm (0.031 - 0.035 in)
Idle speed		1,700 ± 100 rpm
Recommended engine oil		Honda 4-stroke motorcycle oil API Service Classification SG or higher, excluding oils marked as "Energy Conserving" or "Resource Conserving," SAE 10W-30, JASO T 903 standard MB

Engine oil capacity	After draining	0.8 L (0.8 US qt, 0.7 Imp qt)
	After draining & cleaning	0.85 L (0.90 US qt, 0.75 Imp qt)
	After disassembly	0.9 L (1.0 US qt, 0.8 Imp qt)
Transmission oil capacity	After draining	0.12 L (0.13 US qt, 0.11 Imp qt)
	After disassembly	0.14 L (0.15 US qt, 0.12 Imp qt)
Recommended brake fluid		Honda DOT 3 or DOT 4 Brake Fluid
Recommended coolant		Pro Honda HP Coolant
Cooling system capacity		0.50 L (0.53 US qt, 0.44 Imp qt)

Specifications

■ Bulbs

Headlight	LED
Brakelight/Taillight	12 V-21/5 W
Front turn signal	12 V-10 W × 2
Rear turn signal	12 V-10 W × 2
License plate light	12 V-5 W
Position light	LED

■ Fuses

Main fuse	20 A
Other fuse	10 A, 7.5 A

