

**CBR600R3**

**OWNER'S MANUAL**



This manual should be considered a permanent part of the vehicle and should remain with the vehicle when it is resold.

This publication includes the latest production information available before printing. Honda Motor Co., Ltd. reserves the right to make changes at any time without notice and without incurring any obligation.

No part of this publication may be reproduced without written permission.

The vehicle pictured in this owner's manual may not match your actual vehicle.

# Welcome

Congratulations on your purchase of a new Honda vehicle. Your selection of a Honda makes you part of a worldwide family of satisfied customers who appreciate Honda's reputation for building quality into every product.

To ensure your safety and riding pleasure:

- Read this owner's manual carefully.
- Follow all recommendations and procedures contained in this manual.
- Pay close attention to safety messages contained in this manual and on the vehicle.

- The following codes in this manual indicate each destination.
- The illustrations here in are based on the CBR600R3 ED type.

## Destination Codes

---

### Code

### Destination

### CBR600R3

ED, II ED	European direct sale, Hong Kong, Singapore, Turkey, UK, Israel, Serbia,
GS	Saudi Arabia, UAE, Oman, Kuwait, Bahrain, Qatar

---

\*The specifications may vary with each locale.

## A Few Words About Safety

Your safety, and the safety of others, is very important. Operating this vehicle safely is an important responsibility.

To help you make informed decisions about safety, we have provided operating procedures and other information on safety labels and in this manual. This information alerts you to potential hazards that could hurt you or others.

Of course, it is not practical or possible to warn you about all hazards associated with operating or maintaining a vehicle. You must use your own good judgement.

You will find important safety information in a variety of forms, including:

- Safety labels on the vehicle
- Safety Messages preceded by a safety alert symbol  and one of three signal words: DANGER, WARNING, or CAUTION.

These signal words mean:

### **DANGER**

You **WILL** be **KILLED** or **SERIOUSLY HURT** if you don't follow instructions.

### **WARNING**

You **CAN** be **KILLED** or **SERIOUSLY HURT** if you don't follow instructions.

### **CAUTION**

You **CAN** be **HURT** if you don't follow instructions.

**Other important information is provided under the following titles:**

**NOTICE** Information to help you avoid damage to your vehicle, other property, or the environment.

# Contents

**Vehicle Safety** P. 2

**Operation Guide** P. 20

**Maintenance** P. 108

**Troubleshooting** P. 154

**Information** P. 166

**Specifications** P. 181

# Vehicle Safety

This section contains important information for safe riding of your vehicle.  
Please read this section carefully.

<b>Safety Guidelines</b> .....	P. 3
<b>Image Labels</b> .....	P. 7
<b>Safety Precautions</b> .....	P. 13
<b>Riding Precautions</b> .....	P. 14
<b>Accessories &amp; Modifications</b> .....	P. 18
<b>Loading</b> .....	P. 19

## Safety Guidelines

Follow these guidelines to enhance your safety:

- Perform all routine and regular inspections specified in this manual.
- Stop the engine and keep sparks and flames away before filling the fuel tank.
- Do not run the engine in enclosed or partly enclosed areas. Carbon monoxide in exhaust gases is toxic and can kill you.

### Always Wear a Helmet

It's a proven fact: helmets and protective apparel significantly reduce the number and severity of head and other injuries. So always wear an approved helmet and protective apparel. ➤ P. 13

### Before Riding

Make sure that you are physically fit, mentally focused, and free of alcohol and drugs. Check that you and your passenger are both wearing an approved helmet and protective apparel. Instruct your passenger on holding onto the seat strap or your waist, leaning with you in turns, and keeping their feet on the footpegs, even when the vehicle is stopped.

### Take Time to Learn & Practice

Even if you have ridden other vehicles, practice riding in a safe area to become familiar with how this vehicle works and handles, and to become accustomed to the vehicle's size and weight.

### **Ride Defensively**

Always pay attention to other vehicles around you, and do not assume that other drivers see you. Be prepared to stop quickly or perform an evasive maneuver.

### **Make Yourself Easy to See**

Make yourself more visible, especially at night, by wearing bright reflective clothing, positioning yourself so other drivers can see you, signaling before turning or changing lanes, and using your horn when necessary.

### **Ride within Your Limits**

Never ride beyond your personal abilities or faster than conditions warrant. Fatigue and inattention can impair your ability to use good judgement and ride safely.

### **Don't Drink or Use Drugs and Ride**

Alcohol or drugs and riding don't mix. Even one alcoholic drink can reduce your ability to respond to changing conditions, and your reaction time gets worse with every additional drink. The same is true for drug use. Don't drink or use and ride, and don't let your friends do it either.



### Keep Your Honda in Safe Condition

It's important to keep your vehicle properly maintained and in safe riding condition. Inspect your vehicle before every ride and perform all recommended maintenance. Never exceed load limits (➤ P. 19), and do not modify your vehicle or install accessories that would make your vehicle unsafe (➤ P. 18).

### If You are Involved in a Crash

Personal safety is your first priority. If you or anyone else has been injured, take time to assess the severity of the injuries and whether it is safe to continue riding. Call for emergency assistance if needed. Also follow applicable laws and regulations if another person or vehicle is involved in the crash.

If you decide to continue riding, first turn the ignition switch to the **○** (Off) position, and evaluate the condition of your vehicle. Inspect for fluid leaks, check the tightness of critical nuts and bolts, and check the handlebars, control levers, brakes, and wheels. Ride slowly and cautiously.

Your vehicle may have suffered damage that is not immediately apparent. Have your vehicle thoroughly checked at a qualified service facility as soon as possible.

### Carbon Monoxide Hazard

Exhaust contains poisonous carbon monoxide, a colourless, odorless gas. Breathing carbon monoxide can cause loss of consciousness and may lead to death.

If you run the engine in a confined or even partly enclosed area, the air you breathe could contain a dangerous amount of carbon monoxide.

Never run your vehicle inside a garage or other enclosure.

### **WARNING**

Running the engine of your vehicle while in an enclosed or even partially enclosed area can cause a rapid build-up of toxic carbon monoxide gas.

Breathing this colourless, odorless gas can quickly cause unconsciousness and lead to death.

Only run your vehicle's engine when it is located in a well ventilated area outdoors.

## Image Labels

The following pages describe the label meanings. Some labels warn you of potential hazards that could cause serious injury. Others provide important safety information. Read this information carefully and don't remove the labels.

If a label comes off or becomes hard to read, contact your dealer for a replacement.

There is a specific symbol on each label. The meanings of each symbol and label are as follows.



Read instructions contained in Owner's Manual carefully.



Read instructions contained in Shop Manual carefully. In the interest of safety, take the vehicle to be serviced only by your dealer.



**DANGER (with RED background)**

You WILL be KILLED or SERIOUSLY HURT if you don't follow instructions.

**WARNING (with ORANGE background)**

You CAN be KILLED or SERIOUSLY HURT if you don't follow instructions.

**CAUTION (with YELLOW background)**

You CAN be HURT if you don't follow instructions.



### **BATTERY LABEL DANGER**

- Keep flame and spark away from the battery. Battery produce explosive gas that can cause explosion.
- Wear the eye protection and rubber gloves when handling the battery, or you can get burned or lose your eyesight by the battery electrolyte.
- Do not allow children and other people to touch a battery unless they understand proper handling and hazards of the battery very well.
- Handle the battery electrolyte with extreme care as it contains dilute sulfuric acid. Contact with your skin or eyes can burn you or cause loss of your eyesight.
- Read this manual carefully and understand it before handling the battery. Neglect of the instructions can cause personal injury and damage to the vehicle.
- Do not use a battery with the electrolyte at or below the lower level mark. It can explode causing serious injury.



**RADIATOR CAP LABEL**  
**DANGER**

NEVER OPEN WHEN HOT.

Hot coolant will scald you.

Relief pressure valve begins to open at **1.1 kgf/cm<sup>2</sup>**.

## ACCESSORIES AND LOADING WARNING LABEL

ED, II ED type

### ACCESSORIES AND LOADING

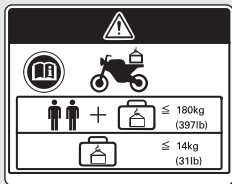

- The safety stability and handling of this vehicle may be affected by the addition of accessories and luggage.
- Read carefully the instructions contained in user's manual and installation guide before installing any accessory.
- The total weight of accessories and luggage added to rider's and passenger's weight should not exceed **180 kg (397 lb)**, which is the maximum weight capacity.
- The luggage weight must not exceed **14 kg (31 lb)** under any circumstances.
- The fitting of large fork-mounted or large handlebar mounted fairing is not recommended.



## REAR CUSHION LABEL

GAS FILLED

Do not open. Do not heat.

**TYRE INFORMATION & DRIVE CHAIN LABEL**

Cold tyre pressure:

[Driver only]

Front

**250 kPa (2.50 kgf/cm<sup>2</sup>, 36 psi)**

Rear

**290 kPa (2.90 kgf/cm<sup>2</sup>, 42 psi)**

[Driver and passenger]

Front

**250 kPa (2.50 kgf/cm<sup>2</sup>, 36 psi)**

Rear

**290 kPa (2.90 kgf/cm<sup>2</sup>, 42 psi)**

Keep chain adjusted and lubricated.

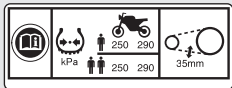
Freeplay **30 - 40 mm (1.2 - 1.6 in)**

### GS type



### ED, II ED type



### **SAFETY REMINDER LABEL**

For your protection, always wear helmet, protective apparel.

### GS type

### **FUEL LABEL**

Unleaded petrol only  
ETHANOL up to 10 % by volume  
Premium Recommended

### ED, II ED type

### **FUEL LABEL**

Unleaded petrol only  
ETHANOL up to 10 % by volume  
Research Octane Number (RON) 95 or higher



## Safety Precautions

- Ride cautiously and keep your hands on the handlebars and feet on the footpegs.
- Instruct your passenger to keep their hands on the seat strap or your waist and their feet on the footpegs while riding.
- Always consider the safety of your passenger, as well as other drivers and riders.

### Protective Apparel

Make sure that you and any passenger are wearing an approved helmet, eye protection, and high-visibility protective clothing. Avoid wearing loose clothes that could get caught on any part of the vehicle. Ride defensively in response to weather and road conditions.

#### ■ Helmet

Safety-standard certified, high-visibility, correct size for your head

- Must fit comfortably but securely, with the chin strap fastened

- Face shield with unobstructed field of vision or other approved eye protection

### **⚠ WARNING**

Not wearing a helmet increases the chance of serious injury or death in a crash.

Make sure that you and any passenger always wear an approved helmet and protective apparel.

#### ■ Gloves

Full-finger leather gloves with high abrasion resistance

#### ■ Boots or Riding Shoes

Sturdy boots with non-slip soles and ankle protection

#### ■ Jacket and Trousers

Protective, highly visible, long-sleeved jacket and durable trousers for riding (or a protective suit)

## Riding Precautions

### Running-in Period

During the first 500 km (300 miles) of running, follow these guidelines to ensure your vehicle's future reliability and performance.

- Avoid full-throttle starts and rapid acceleration.
- Avoid hard braking and rapid down-shifts.
- Ride conservatively.

### Brakes

Observe the following guidelines:

- Avoid excessively hard braking and downshifting.
  - ▶ Sudden braking can reduce the vehicle's stability.
  - ▶ Where possible, reduce speed before turning; otherwise you risk sliding out.

- Exercise caution on low traction surfaces.
  - ▶ The tyres slip more easily on such surfaces and braking distances are longer.
- Avoid continuous braking.
  - ▶ Repeated braking, such as when descending long, steep slopes can seriously overheat the brakes, reducing their effectiveness. Use engine braking with intermittent use of the brakes to reduce speed.
- For full braking effectiveness, operate both the front and rear brakes together.

### **| Anti-lock Brake System (ABS)**

This model is equipped with an Anti-lock Brake System (ABS) designed to help prevent the brakes from locking up during hard braking. The ABS functions with information provided by the IMU (Inertia Measurement Unit).

- ABS does not reduce braking distance. In certain circumstances, ABS may result in a longer stopping distance.
- ABS does not function at speeds below 6 km/h (4 mph).
- The brake lever and pedal may recoil slightly when applying the brakes. This is normal.
- Always use the recommended front/rear tyres and sprockets to ensure correct ABS operation.

### **| Engine Braking**

Engine braking helps slow your vehicle down when you release the throttle. For further slowing action, downshift to a lower gear. Use engine braking with intermittent use of the brakes to reduce speed when descending long, steep slopes.

### **| Wet or Rainy Conditions**

Road surfaces are slippery when wet, and wet brakes further reduce braking efficiency. Exercise extra caution when braking in wet conditions. If the brakes get wet, apply the brakes while riding at low speed to help them dry.

### Parking

- Park on a firm, level surface.
- If you must park on a slight incline or loose surface, park so that the vehicle cannot move or fall over.
- Make sure that high-temperature parts cannot come into contact with flammable materials.
- Do not touch the engine, muffler, brakes and other high-temperature parts until they cool down.
- To reduce the likelihood of theft, always lock the handlebars and remove the key when leaving the vehicle unattended. Use of an anti-theft device is also recommended.

### ■ Parking with the Side Stand

1. Stop the engine.
2. Push the side stand down.

3. Slowly lean the vehicle to the left until its weight rests on the side stand.
4. Turn the handlebars fully to the left.
  - ▶ Turning the handlebars to the right reduces stability and may cause the vehicle to fall.
5. Turn the ignition switch to the  (Lock) position and remove the key. ➤ P. 92

### Refuelling and Fuel Guidelines

Follow these guidelines to protect the engine, fuel system and catalytic converter:

- Use only unleaded petrol.
- Use the recommended octane number. Using lower octane petrol will result in decreased engine performance.
- Do not use fuels containing a high concentration of alcohol. ➤ P. 179
- Do not use stale or contaminated petrol or an oil/petrol mixture.
- Avoid getting dirt or water in the fuel tank.

## Honda Selectable Torque Control

When the Honda Selectable Torque Control (Torque Control) detects rear wheel spin during acceleration, the system will limit the amount of torque applied to the rear wheel based on the Torque Control level selected.

Additionally, the system ease the rapid motion during accelerating based on the Wheelie Control level selected.

Torque Control will allow some wheel spin during acceleration at the lower Torque Control setting levels. Select a level that is appropriate for your skill and riding conditions.

Torque Control does not work during deceleration and will not prevent the rear wheel from skidding due to engine braking. Do not close the throttle suddenly, especially when riding on slippery surfaces.

Torque Control may not compensate for rough road conditions or rapid throttle operation.

Always consider road and weather conditions, as well as your skills and condition, when applying throttle.

If your vehicle gets stuck in mud, snow, or sand, it may be easier to free it by turning off the Torque Control temporarily.

Temporarily turning off Torque Control also may help you maintain control and balance when riding on off-road terrain.

Always use the recommended tyres and sprockets to ensure correct Torque Control operation.

## Accessories & Modifications

We strongly advise that you do not add any accessories that were not specifically designed for your vehicle by Honda or make modifications to your vehicle from its original design. Doing so can make it unsafe. Modifying your vehicle may also void your warranty and make your vehicle illegal to operate on public roads. Before deciding to install accessories on your vehicle, be certain the modification is safe and legal.

### **WARNING**

Improper accessories or modifications can cause a crash in which you can be seriously hurt or killed.

Follow all instructions in this owner's manual regarding accessories and modifications.

Do not pull a trailer with, or attach a sidecar to, your vehicle. Your vehicle was not designed for these attachments, and their use can seriously impair your vehicle's handling.

## Loading

- Carrying extra weight affects your vehicle's handling, braking and stability. Always ride at a safe speed and never exceed 130 km/h (80 mph) for the load you are carrying.
- Avoid carrying an excessive load and keep within specified load limits.  
**Maximum weight capacity / Maximum luggage weight** 📖 P. 181
- Tie all luggage securely, evenly balanced, and close to the centre of the vehicle.
- Do not place objects near the lights or the muffler.

### **WARNING**

Overloading or improper loading can cause a crash and you can be seriously hurt or killed.

Follow all load limits and other loading guidelines in this manual.

# Parts Location

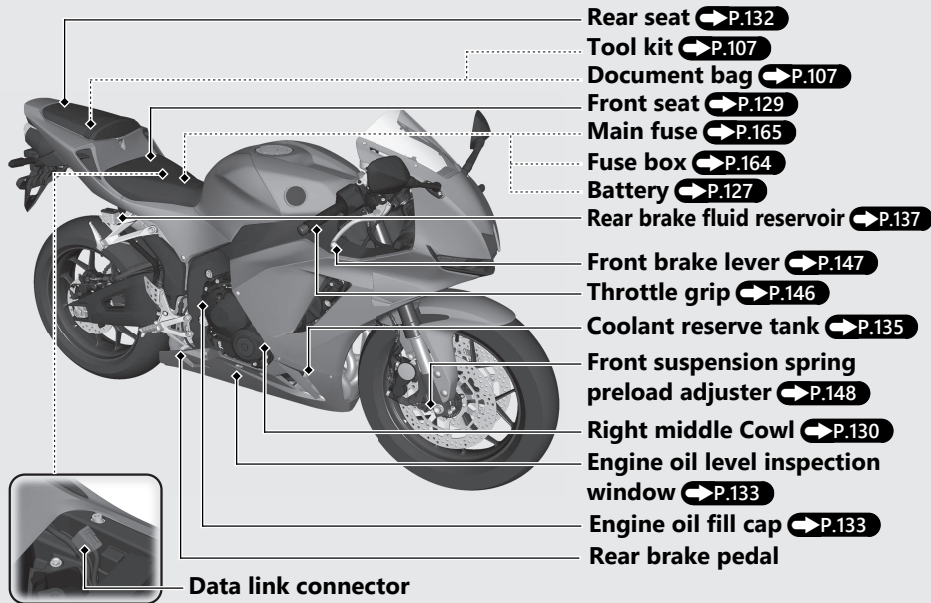



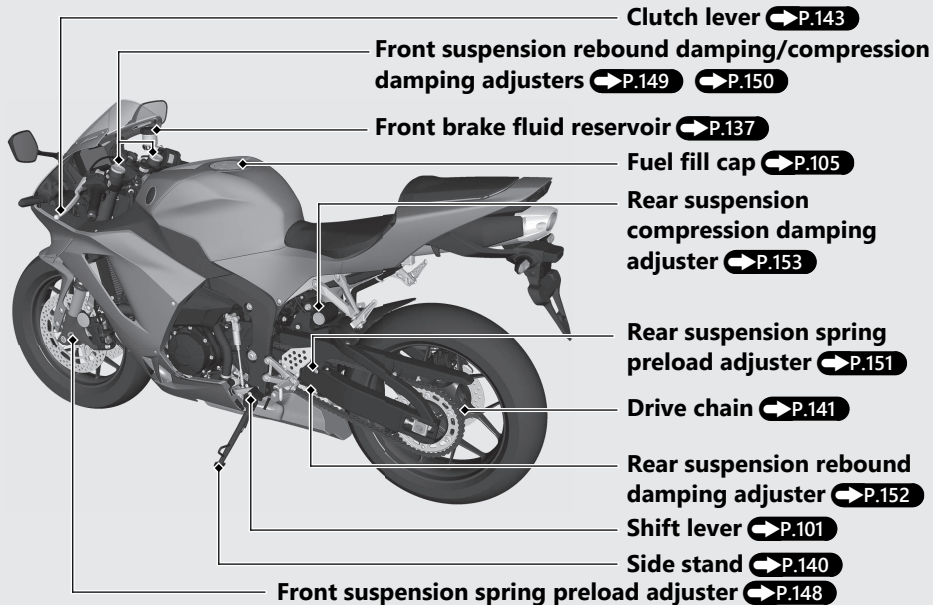

# Instruments

## Street mode

### Clock (12-hour display)

To set the clock: ➔ P.67

### Tachometer

#### NOTICE

Do not operate the engine in the tachometer red zone. Excessive engine speed can adversely affect engine life.

### Speedometer

### Tachometer red zone

(excessive engine rpm range)

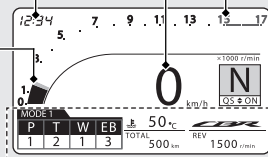

## Display Check

When the ignition switch is turned to the **I** (On) position, the opening symbol will show on the display. If the display itself does not show when it should, have your dealer check for problems.

You can select the street mode or circuit mode display.

To change to the circuit mode: ➔ P.24

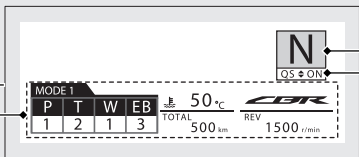

**Multi-information display** ➔ P.25

### **Gear position indicator**

Shows 1st to 6th gear positions. "-" appears when the transmission is not shifted properly.

### **Quick Shifter indicator**

Displays the current status of the Quick Shifter.

**QS OFF** : Quick Shifter system is disabled.

**QS ▲ ON** : Quick Shifter upshifting is enabled.

**QS ▼ ON** : Quick Shifter downshifting is enabled.

**QS ◆ ON** : Quick Shifter upshifting and downshifting are both enabled.

**QUICK SHIFTER:** ➔ P.46

## Instruments *(Continued)*

### Circuit mode

#### To change to the circuit mode :

- Press and hold the **LAP** button with your vehicle stopped.
  - ▶ To return to the street mode display, press and hold the **LAP** button.
- Select the "CIRCUIT" menu on the "DISPLAY" screen. **➡P.43** **➡P.56**
  - ▶ To return to the street mode display, select the "STREET" menu on the "DISPLAY".

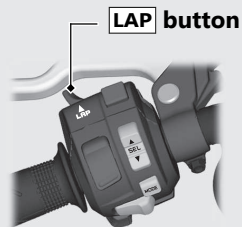
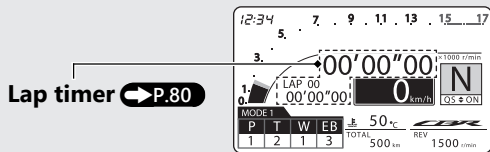

### Display Check

When the ignition switch is turned to the **I** (On) position, the opening symbol will show on the display. If the display itself does not show when it should, have your dealer check for problems.

## Multi-information display

Multi-information display can display the coolant temperature gauge, riding modes, INFO 1, INFO 2 and INFO 3 displays.

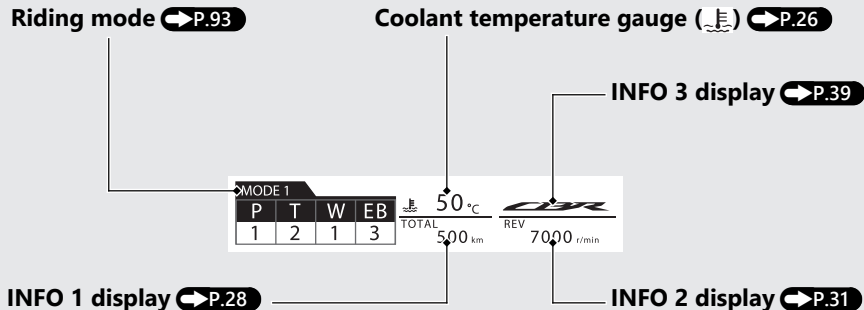

You can change the riding mode, INFO1, INFO 2 and INFO 3 displays of the Multi-information display.

**To switch the multi-information display:** (P.27)

## Instruments *(Continued)*

### Coolant temperature gauge

Display range: 35°C to 132°C

- 34°C or less: "---" is displayed.
- Between 122°C and 131°C:
  - High coolant temperature indicator lights.
  - Coolant temperature digits flash.
- Above 132°C:
  - High coolant temperature indicator lights.
  - "132°C" flashes.
- Even if the engine coolant temperature is low, the cooling fan may start running when you rev up the engine. This is normal.

### Pop-up information

In the following cases, the INFO 3 display, or the INFO 3 display and the coolant temperature gauge change to a pop-up information display.

- When an inspection time of your vehicle is approaching.
- When your vehicle has helpful information.
- When your vehicle has a problem with the PGM-FI system.

**Information of the pop-up information:**  **P.84**

## To switch the multi-information display

To select the display area, repeatedly press the **MODE** button.

- ▶ Can not select the INFO 3 display while pop-up information displayed. ➡ P.84

If the **MODE** button is not pressed within 10 seconds, the display returns to the riding mode display.

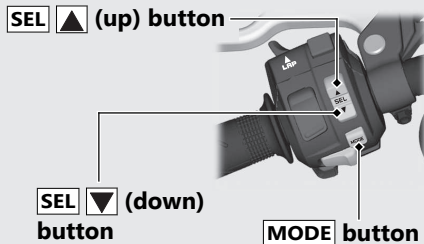

### Riding mode ➡ P.93



### INFO 3 display ➡ P.39

➡ Press the **MODE** button

### INFO 1 display ➡ P.28



### INFO 2 display ➡ P.31



## Instruments *(Continued)*

### INFO 1 display

You can select the following:

- Odometer [TOTAL]
- Tripmeter [TRIP A/B]

### Changing the INFO 1 display

- 1 Select the INFO 1 display. 
- 2 Press the **SEL**  (up) or **SEL**  (down) button until the desired indication is displayed.
- 3 Press the **MODE** button. The INFO 1 display is set, and then the display moves to the INFO 2 display.

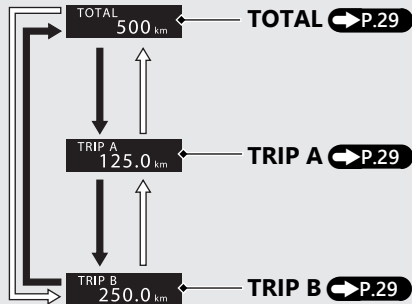



## Odometer [TOTAL]

Total distance ridden.

A black rectangular display showing the word "TOTAL" in white capital letters at the top left, and the number "500" in a large white font in the center, with "km" in a smaller white font to its right.

When "-----" is displayed, go to your dealer for service.

## Tripmeter A/B [TRIP A/B]

Distance ridden since the tripmeter was reset.

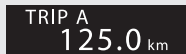
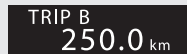
A black rectangular display showing the words "TRIP A" in white capital letters at the top left, and the number "125.0" in a large white font in the center, with "km" in a smaller white font to its right.A black rectangular display showing the words "TRIP B" in white capital letters at the top left, and the number "250.0" in a large white font in the center, with "km" in a smaller white font to its right.

When "----.-" is displayed, go to your dealer for service.

**To reset the tripmeter:**  **P.30**

## Instruments *(Continued)*

### To Reset the Tripmeter and Tripmeter A Fuel Consumption

To reset tripmeter A and tripmeter A fuel consumption together, press and hold the **MODE** button with the tripmeter A or tripmeter A fuel consumption displayed.

#### Tripmeter A

TRIP A  
125.0 km

or

#### Tripmeter A fuel consumption

TRIP A CONS.  
50.0 L



TRIP A  
0.0 km

or

TRIP A CONS.  
-.- L

To reset the tripmeter B, press and hold the **MODE** button with the tripmeter B displayed.

TRIP B  
250.0 km

**Tripmeter B**









TRIP B  
0.0 km

## INFO 2 display

You can select the following:

- Numerical tachometer display [REV]
- Current fuel mileage [INST. CONS.]
- Average fuel mileage [AVE. CONS.]
- Tripmeter A fuel consumption [TRIP A CONS.]
- Average speed [AVG. SPD.]
- Elapsed time [ELAPSED]
- Available riding distance [RANGE]  
(Only when reserve fuel mode)
- Amount of remaining fuel [REMAIN]  
(Only when reserve fuel mode)

### Changing the INFO 2 display

- 1 Select the INFO 2 display.  **P.27**
- 2 Press the   (up) or   (down) button until the desired display is displayed.
- 3 Press the  button. The INFO 2 display is set, and display moves to the INFO 3 display.

## Instruments (Continued)

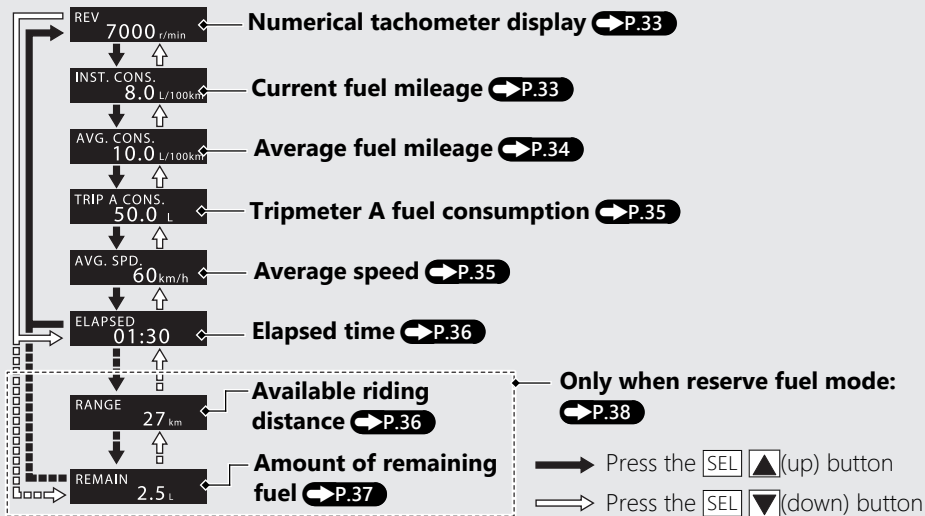

When the low fuel indicator lights and the low fuel pop-up information appear, INFO 3 display will automatically switch to the amount of remaining fuel display.

**Numerical tachometer display [REV]**

Displays engine revolutions per minutes.

Display range: 0 to 17,000 r/min (rpm)

- Above 17,000 r/min (rpm): "17000" is displayed.



REV  
7000 r/min

**Current fuel mileage [INST. CONS.]**

Displays the current instant fuel mileage.

Display range:

0.0 to 99.9 L/100km (km/L or MPG or mile/L )

- When your speed is less than 7 km/h (5 mph): "--.-" is displayed.
- Above 99.9 L/100km: "--.-" is displayed.
- Above 99.9 km/L (MPG or mile/L): "99.9" is displayed.



INST. CONS.  
8.0 L/100km

When "--.-" is displayed except for the above-mentioned cases, go to your dealer for service.

## Instruments *(Continued)*

### Average fuel mileage [AVG. CONS.]

Displays the average fuel mileage since the average fuel mileage was reset.

Display range:

0.0 to 99.9 L/100km (km/L or MPG or mile/L )

- Above 99.9 L/100km: "--.-" is displayed.
- Above 99.9 km/L (MPG or mile/L ): "99.9" is displayed.
- When the average fuel mileage is reset: "--.-" is displayed.

AVG. CONS.  
10.0 L/100km

When "--.-" is displayed except for the above-mentioned cases, go to your dealer for service.

### To Reset the Average Fuel Mileage

Press and hold the **MODE** button with the average fuel mileage displayed.

AVG. CONS.  
10.0 L/100km

Average fuel  
mileage



AVG. CONS.  
- -.- L/100km

## Tripmeter A fuel consumption [TRIP A CONS.]

Displays the tripmeter A fuel consumption since the tripmeter A was reset.

Display range:

0.0 to 300.0 L (litres) or 0.0 to 300.0 GAL (gallon)

- Above 300 L (litres) or 300 GAL (gallon): "300.0" is displayed.
- When the tripmeter A fuel consumption is reset: "---.-" is displayed.

TRIP A CONS.  
50.0 L

When "---.-" is displayed except for the above-mentioned cases, go to your dealer for service.

**To reset the tripmeter A fuel consumption:**  P.30

## Average speed [AVG. SPD.]

Displays average speed since the engine was started.

Display range:

0 to 299 km/h (0 to 186 mph)

- Initial display: "---" is displayed.
- When your vehicle has traveled less than 0.2 km (0.12 mile) since the engine was started: "---" is displayed.
- When your vehicle operating time is less than 16 seconds since the engine was started: "---" is displayed.

AVG. SPD.  
60 km/h

When "---" is displayed except for the above-mentioned cases, go to your dealer for service.

## Instruments *(Continued)*

### Elapsed time [ELAPSED]

Displays operating time since the engine was started.

Display range:

00:00 to 99:59 (hours:minutes)

- Above 99:59: returns to 00:00.

When the ignition switch is turned to the  (Off) position, the elapsed time is reset.



ELAPSED  
01:30

When "--:--" is displayed, go to your dealer for service.

### Available riding distance [RANGE] (Only reserve fuel mode)

When the low fuel indicator lights and the low fuel pop-up information appears, the estimated available riding distance is indicated.

Display range:

99 to 0 km (mile)

- Above 99 km (mile): "99" is displayed.
- Below 1.0 L (0.2 GAL): "--" is displayed.

The indicated available riding distance is calculated based on the riding states, and the indicated figure may not always be the actual allowable distance.



RANGE  
27 km

When "--" is displayed except for the above-mentioned cases, go to your dealer for service.



## **Amount of remaining fuel [REMAIN] (Only reserve fuel mode)**

When the low fuel indicator lights and the low fuel pop-up information appears, the estimated amount of remaining fuel can be selected.

Display range:

4.0 to 1.0 L (litres) or 0.9 to 0.2 GAL (gallon)

- Below 1.0 L (0.2 GAL): “-.-” is displayed.

The amount of remaining fuel is calculated based on the riding states.

The indicated amount of remaining fuel may be different from the actual amount.



REMAIN  
2.5 L

When “-.-” is displayed except for the above-mentioned cases, go to your dealer for service.

## Instruments *(Continued)*

### Reserve Fuel Mode

When the low fuel indicator lights and the low fuel pop-up information appears, the available riding distance is indicated, and the amount of remaining fuel display can be selected.

You should refill the tank as soon as possible.

Remaining fuel amount turned to the reserve fuel mode:

4.0 L (1.1 US gal, 0.9 Imp gal)

### Low fuel pop-up information

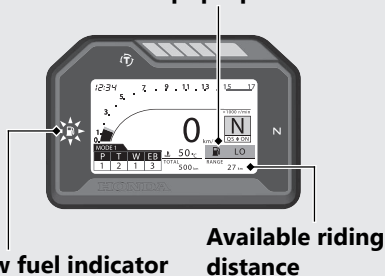

**Low fuel indicator**

**Available riding distance**

After refuelling more than the reserve amount, the display returns to normal when the ignition switch has been **I** (On) position for about a minute.

## INFO 3 display

You can select the following:

- CBR Logo
- Shift indicator set value [REV IND NE]
- Throttle grip angle [GRIP ANGLE]
- Battery voltage [VOLTAGE]
- Date [DATE]
- User letter
- Blank display

## Changing the INFO 3 display

- 1 Select the INFO 3 display. **➡P.27**
- 2 Press the **SEL ▲** (up) or **SEL ▼** (down) button until the desired display is displayed.
- 3 Press the **MODE** button. The INFO 3 display is set, and then the display moves to the riding mode display.

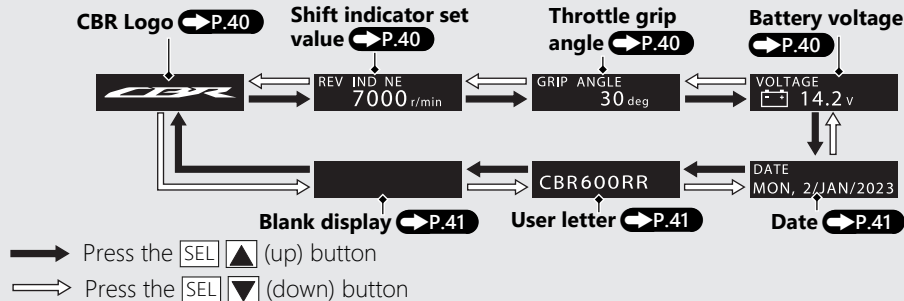

## Instruments *(Continued)*

### CBR logo

Displays the CBR logo.



### Shift indicator set value [REV IND NE]

Displays the shift indicator set value.

Display range: OFF or 4,000 - 17,500 r/min



To set the shift indicator:  P.58

### Throttle grip angle [GRIP ANGLE]

Displays the throttle grip angle during operation.



When "--" is displayed, go to your dealer for service.

### Battery voltage [VOLTAGE]

Displays the current voltage.



**Date [DATE]**

Displays the today's date.

Display range:

Day of the week: MON to SUN

DAY: 1 to 31

Month: JAN to DEC

Year: 2010 to 2099

DATE  
MON, 2/JAN/2023

**To set the Date:**  P.67

**User letter**

Displays the characters of user's choice.

CBR600RR

**To set the USER LETTER:**  P.61

**Blank display**

Display the blank.



## Instruments *(Continued)*

### Setting mode



You can perform the following:



- **FUNCTION** ➡ **P.45**
  - ▶ Quick Shifter setting
  - ▶ Setting the HISS
- **LAP TIME** ➡ **P.52**
  - ▶ Checking the lap time
  - ▶ Resetting the lap time
- **DISPLAY** ➡ **P.55**
  - ▶ Changing the display mode
  - ▶ Setting the shift indicator
  - ▶ Setting the backlight brightness
  - ▶ Setting the back ground
  - ▶ Setting the user letter
  - ▶ Setting the favorite
- **GENERAL** ➡ **P.66**
  - ▶ Setting the date and clock
  - ▶ Setting each meter unit
  - ▶ Resetting to factory default settings
- **SERVICE** ➡ **P.74**
  - ▶ Checking the next inspection schedule
  - ▶ QUICK SHIFTER  
"INITIALIZE" and "EQUIPMENT" are displayed but not selectable.
  - ▶ "SPORTS KIT ECU USAGE" is displayed but not usable.

## To Shift to the Setting Mode

Press and hold the **MODE** button and **SEL**  (up) or **SEL**  (down) button until main menu screen is displayed with your vehicle stopped.

### Main menu screen

12:34	SETTING	0 km/h
SERVICE		DOWN LVL
EXIT		
FUNCTION	QUICKSHIFTER	UP
LAP TIME	HISS INDICATOR	DOWN
DISPLAY		UP LVL

Select a menu by pressing the **SEL**  (up) or **SEL**  (down) button and press the **MODE** button.

- ▶ Press and hold the **SEL**  (up) or **SEL**  (down) button to move the menu quickly.

## Instruments *(Continued)*

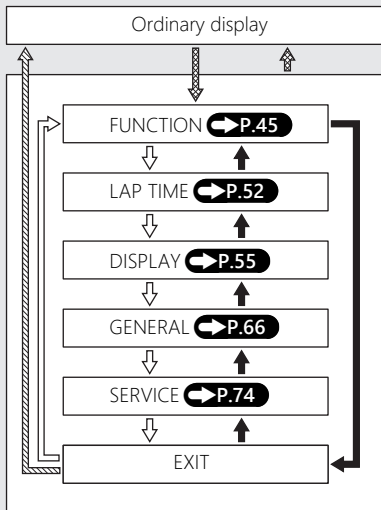

Press the **MODE** button

Press and hold the **MODE** button and **SEL** ▲ (up) or **SEL** ▼ (down) button

Press the **SEL** ▲ (up) button

Press the **SEL** ▼ (down) button

### To end the setting

Select the “EXIT” menu on the main menu screen, or press and hold the **MODE** button and **SEL** ▲ (up) or **SEL** ▼ (down) button. Also, the setting mode is ended when your vehicle speed reaches approximately 1 km/h (1 mph).

▶ Press and hold the **MODE** button and **SEL** ▲ (up) or **SEL** ▼ (down) button to return to the ordinary display.

Note that doing so cancels the settings left incomplete.



## FUNCTION

### To Set the FUNCTION Menu

- 1 Select the "FUNCTION" menu on the main menu screen. ➡ P.43
- 2 Select a menu by pressing the [SEL] ▲ (up) or [SEL] ▼ (down) button and press the [MODE] button.

### To end the setting

Select the ◀ (return) on the menu screen.  
The display returns to the "FUNCTION" menu on the main menu screen.

### "FUNCTION" is selected

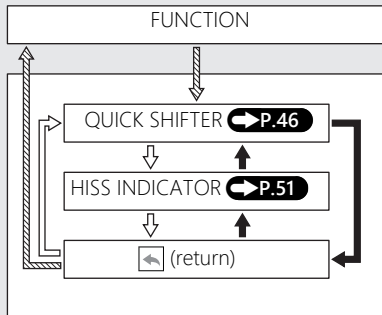

➡ Press the [MODE] button

➡ Press the [SEL] ▲ (up) button

➡ Press the [SEL] ▼ (down) button

## Instruments *(Continued)*

### QUICK SHIFTER

You can change the setting of the Quick Shifter.

- UP:  
To select "ON" (activate) or "OFF" (deactivate) for upshifting ➡ **P.47**
- DOWN:  
To select "ON" (activate) or "OFF" (deactivate) for downshifting ➡ **P.48**
- UP LVL:  
To select the shift pedal load level for activating the Quick Shifter when upshifting ➡ **P.49**
- DOWN LVL:  
To select the shift pedal load level for activating the Quick Shifter when downshifting ➡ **P.50**





### To end the setting

Select the  (return) on the menu screen. The display returns to the "QUICKSHIFTER" menu on the "FUNCTION" screen.



### To use the Quick Shifter ➡ **P.102**

## UP

You can select "ON" (activate) or "OFF" (deactivate) for upshifting with the Quick Shifter.

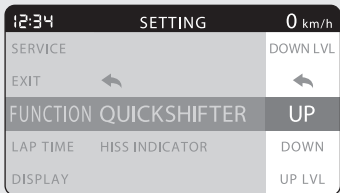
- 1 Select the "UP" using the **SEL**  (up) or **SEL**  (down) button, and press the **MODE** button.
  - ▶ Press and hold the **SEL**  (up) or **SEL**  (down) button to move the menu quickly.



- 2 Select "ON" (activate) or "OFF" (deactivate) using the **SEL**  (up) or **SEL**  (down) button.

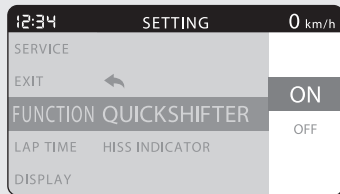





- 3 Press the **MODE** button. The "UP" setting is set, and then the display returns to the upper level hierarchy.

## Instruments *(Continued)*



### DOWN

You can select "ON" (activate) or "OFF" (deactivate) for downshifting with the Quick Shifter.

- 1 Select the "DOWN" using the **SEL**  (up) or **SEL**  (down) button, and press the **MODE** button.

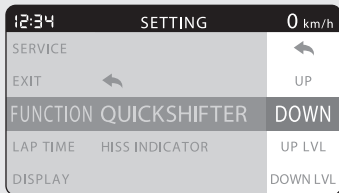
- ▶ Press and hold the **SEL**  (up) or **SEL**  (down) button to move the menu quickly.





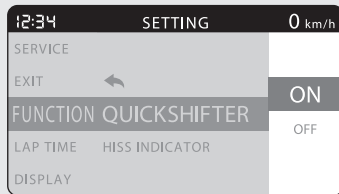

- 2 Select "ON" (activate) or "OFF" (deactivate) using the **SEL**  (up) or **SEL**  (down) button.









- 3 Press the **MODE** button. The "DOWN" setting is set, and then the display returns to the upper level hierarchy.



## UP LVL

You can select the shift pedal load level for activating the Quick Shifter when upshifting.

- 1 Select the "UP LVL" using the **SEL**  (up) or **SEL**  (down) button, and press the **MODE** button.
  - ▶ Press and hold the **SEL**  (up) or **SEL**  (down) button to move the menu quickly.

12:34		SETTING	0 km/h
SERVICE			UP
EXIT			DOWN
FUNCTION QUICKSHIFTER			UP LVL
LAP TIME	HISS INDICATOR		DOWN LVL
DISPLAY			

- 2 Select one of the three levels using the **SEL**  (up) or **SEL**  (down) button.
  - ▶ Press and hold the **SEL**  (up) or **SEL**  (down) button to move the menu quickly.
  - ▶ Available setting range:  
1 (light operation) to 3 (heavy operation)





12:34		SETTING	0 km/h
SERVICE			
EXIT			1
FUNCTION QUICKSHIFTER			2
LAP TIME	HISS INDICATOR		3
DISPLAY			



- 3 Press the **MODE** button. The "UP LVL" setting is set, and then the display returns to the upper level hierarchy.





## Instruments *(Continued)*



### DOWN LVL

You can select the shift pedal load level for activating the Quick Shifter when downshifting.

- 1 Select the "DOWN LVL" using the **SEL**  (up) or **SEL**  (down) button, and press the **MODE** button.
  - ▶ Press and hold the **SEL**  (up) or **SEL**  (down) button to move the menu quickly.

12:34		SETTING	0 km/h
SERVICE		DOWN	
EXIT		UP LVL	
FUNCTION QUICKSHIFTER		DOWN LVL	
LAP TIME	HISS INDICATOR		
DISPLAY		UP	



- 2 Select one of the three levels using the **SEL**  (up) or **SEL**  (down) button.
  - ▶ Press and hold the **SEL**  (up) or **SEL**  (down) button to move the menu quickly.
  - ▶ Available setting range:  
1 (light operation) to 3 (heavy operation)

12:34		SETTING	0 km/h
SERVICE			
EXIT			1
FUNCTION QUICKSHIFTER			2
LAP TIME	HISS INDICATOR		3
DISPLAY			

- 3 Press the **MODE** button. The "DOWN LVL" setting is set, and then the display returns to the upper level hierarchy.

## HISS INDICATOR

You can select the blinking or turning off the HISS indicator.

- 1 Select the "ON" (blinks) or "OFF" (off) using the **SEL**  (up) or **SEL**  (down) button.

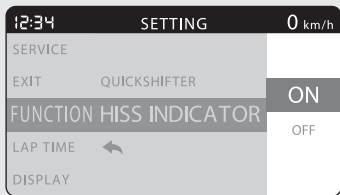

- 2 Press the **MODE** button. The HISS indicator setting is set, and then the display returns to the upper level hierarchy.

## Instruments *(Continued)*

### LAP TIME

#### To Set the LAP TIME Menu

- 1 Select the "LAP TIME" menu on the main menu screen. **➡ P.43**
- 2 Select the menu by pressing the **[SEL] ▲** (up) or **[SEL] ▼** (down) button, and press the **[MODE]** button.

#### To end the setting

Select the **[↩]** (return) on the menu screen. The display returns to the "LAP TIME" menu on the main menu screen.

#### "LAP TIME" is selected

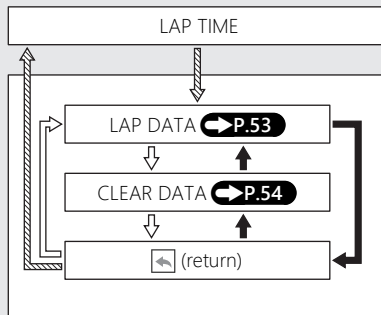

**➡** Press the **[MODE]** button

**➡** Press the **[SEL] ▲** (up) button

**➡** Press the **[SEL] ▼** (down) button



## LAP DATA

The history of recorded lap time and information are displayed.

To display the other lap information, press the **[SEL]** **▲** (up) or **[SEL]** **▼** (down) button.

To display the maximum acceleration, maximum deceleration, maximum left bank

angle and maximum right bank angle information, press the **[LAP]** button.

To end the display of lap time history, press the **[MODE]** button. The display returns to the upper level hierarchy.

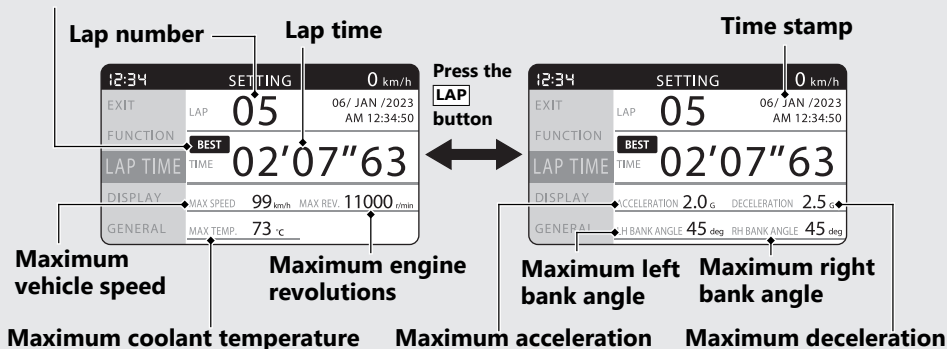

**To use the Lap Timer** **P.80**

### Best icon (Appears when the fastest lap time displayed.)



## Instruments *(Continued)*

### CLEAR DATA

- 1 Select "NO" (not clear) or "YES" (clear) using the **SEL**  (up) or **SEL**  (down) button.
- 2 Press the **MODE** button. The display returns to the upper level hierarchy.

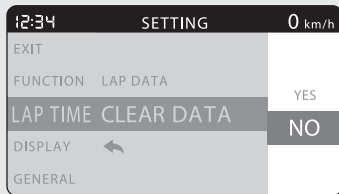

To use the Lap Timer  P.80

## DISPLAY

### To Set the DISPLAY Menu

- 1 Select the "DISPLAY" menu on the main menu screen. ➡ P.43
- 2 Select the menu by pressing the **SEL** **▲** (up) or **SEL** **▼** (down) button and press the **MODE** button.

### To end the setting

Select the **◀** (return) on the menu screen. The display returns to the "DISPLAY" menu on the main menu screen.

➡ Press the **MODE** button

➡ Press the **SEL** **▲** (up) button

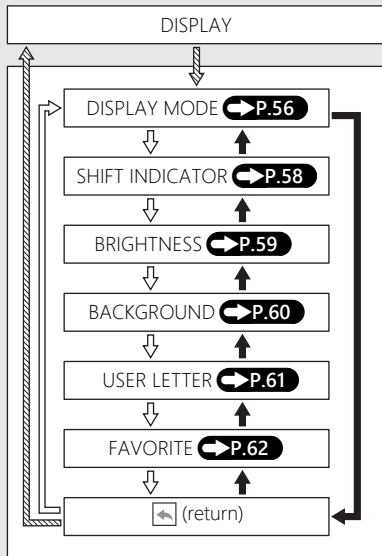

➡ Press the **SEL** **▼** (down) button

### "DISPLAY" is selected



## Instruments *(Continued)*

### DISPLAY MODE

- 1 Select "STREET", "MECHANIC" or "CIRCUIT" using the **SEL**  (up) or **SEL**  (down) button.

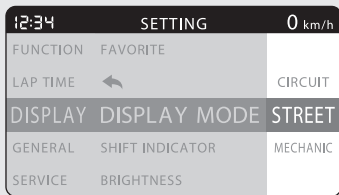

- 2 When the "STREET" or "CIRCUIT" is selected  
Press the **MODE** button. The display mode setting is set, and then the display returns to the upper level hierarchy.  
**When the "MECHANIC" is selected**  
Press the **MODE** button. The display moves to the mechanic mode.

- 3 When the "MECHANIC" is selected  
Press the **MODE** button. The mechanic mode ends, and then the display returns to the upper level hierarchy.  
▶ The display mode returns to the previously selected mode.

## Mechanic Mode

Displays the current information of the vehicle.

Displays the following information:

- Tachometer
- Gear position
- Throttle grip position
- Coolant temperature
- Battery voltage



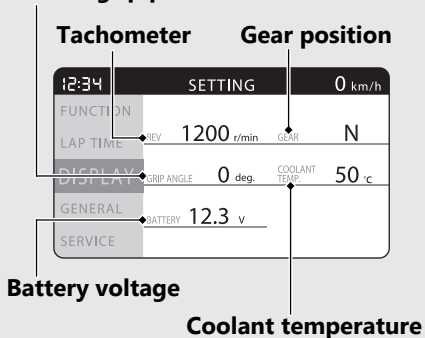

## Throttle grip position



## Instruments *(Continued)*

### SHIFT INDICATOR

You can change the setting of the shift indicators.

- 1 Select the "OFF" (deactivate) or an engine revolution at which the shift indicators start blinking using the **SEL**  (up) or **SEL**  (down) button.
  - ▶ Press and hold the **SEL**  (up) or **SEL**  (down) button to move the menu quickly.
  - ▶ The value increases by 200 r/min (rpm) increments.
  - ▶ Available setting range:  
4,000 - 17,500 r/min (rpm)

- 2 Press the **MODE** button. The shift indicator setting is set, and then the display returns to the upper level hierarchy.

12:34		SETTING	0 km/h
FUNCTION			17400
LAP TIME	DISPLAY MODE		17500
			OFF
DISPLAY	SHIFT INDICATOR		4000 <small>r/min</small>
GENERAL	BRIGHTNESS		4200
			4400
SERVICE	BACKGROUND		4600





### Information of the Shift Indicator:

 P.89

## BRIGHTNESS

You can adjust the backlight brightness to one of the eight levels or select the auto adjustment.

### Automatic brightness control P.171



- 1 Select the "AUTO" (auto adjustment) or brightness level using the **SEL**  (up) or **SEL**  (down) button.
  - ▶ Press and hold the **SEL**  (up) or **SEL**  (down) button to move the menu quickly.
- 2 Press the **MODE** button. The backlight brightness setting is set, and then the display returns to the upper level hierarchy.



12:34		SETTING	0 km/h
FUNCTION	DISPLAY MODE		6
LAP TIME	SHIFT INDICATOR		7
			8
<b>DISPLAY</b>		<b>BRIGHTNESS</b>	<b>AUTO</b>
GENERAL	BACKGROUND		1
			2
SERVICE	USER LETTER		3

## Instruments *(Continued)*

### BACKGROUND

You can change the setting of the background to one of the four categories or select the auto adjustment.

- 1 Select the "AUTO", "WHITE", "BLACK", "METALLIC" or "CARBON" using the **SEL**  (up) or **SEL**  (down) button.

  - ▶ Press and hold the **SEL**  (up) or **SEL**  (down) button to move the menu quickly.
- 2 Press the **MODE** button. The background setting is set, and then the display returns to the upper level hierarchy.

12:34		SETTING	0 km/h
FUNCTION	SHIFT INDICATOR	METALLIC	
LAP TIME	BRIGHTNESS	CARBON	
<b>DISPLAY BACKGROUND</b>		<b>AUTO</b>	
GENERAL	USER LETTER	WHITE	
SERVICE	FAVORITE	BLACK	



## USER LETTER

You can select any 10 characters you like.

- 1 Select the first character using the **SEL** **▲** (up) or **SEL** **▼** (down) button until a desired character appears
  - ▶ Press and hold the **SEL** **▲** (up) or **SEL** **▼** (down) button to move the menu quickly.
- 2 Press the **MODE** button. The cursor moves to the next position.
- 3 Repeat the steps 1 and 2 to select characters for the other positions until a desired word is complete.
- 4 When the tenth character is selected, the display returns to the upper level hierarchy.

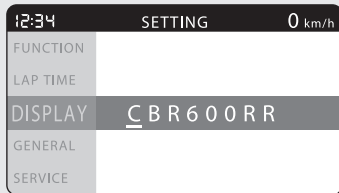

### A list of characters that can be selected

<b>A</b>	<b>B</b>	<b>C</b>	<b>D</b>	<b>E</b>	<b>F</b>	<b>G</b>	<b>H</b>	<b>I</b>
<b>J</b>	<b>K</b>	<b>L</b>	<b>M</b>	<b>N</b>	<b>O</b>	<b>P</b>	<b>Q</b>	<b>R</b>
<b>S</b>	<b>T</b>	<b>U</b>	<b>V</b>	<b>W</b>	<b>X</b>	<b>Y</b>	<b>Z</b>	<b>0</b>
<b>1</b>	<b>2</b>	<b>3</b>	<b>4</b>	<b>5</b>	<b>6</b>	<b>7</b>	<b>8</b>	<b>9</b>
<b>!</b>	<b>"</b>	<b>#</b>	<b>\$</b>	<b>%</b>	<b>&amp;</b>	<b>'</b>	<b>'</b>	<b>(</b>
<b>)</b>	<b>*</b>	<b>+</b>	<b>,</b>	<b>-</b>	<b>.</b>	<b>/</b>	<b>:</b>	<b>;</b>
<b>&lt;</b>	<b>&gt;</b>	<b>=</b>	<b>?</b>	<b>@</b>	<b>^</b>	<b>_</b>		

## Instruments *(Continued)*

### FAVORITE

You can change the indications on the INFO 1, INFO 2, and INFO 3 to the following information by pressing the **LAP** button while the street mode is displayed.

INFO 1:

"TOTAL", "TRIP A" or "TRIP B"

INFO 2:

"REV", "INST.CONST.", "AVG.CONST.", "TRIP A  
CONST.", "AVG.SPD." or "ELAPSED"

INFO 3:





"CBR LOGO", "REV IND NE", "GRIP ANGLE",  
"VOLTAGE", "DATE", "USER LETTER" or a  
blank display

### To end the setting



Select the  (return) on the menu screen.  
The display returns to the "FAVORITE" menu  
on the "DISPLAY" menu screen.



**INFO 1**

You can select the "TOTAL", "TRIP A" or "TRIP B" for INFO 1.

- 1 Select the "INFO 1" using the **SEL**  (up) or **SEL**  (down) button, and press the **MODE** button.
  - ▶ Press and hold the **SEL**  (up) or **SEL**  (down) button to move the menu quickly.

12:34	SETTING	0 km/h
FUNCTION	BACKGROUND	
LAP TIME	USER LETTER	
DISPLAY	FAVORITE	INFO 1
GENERAL		INFO 2
SERVICE	DISPLAY MODE	INFO 3

- 2 Select the "TOTAL", "TRIP A" or "TRIP B" using the **SEL**  (up) or **SEL**  (down) button.

- ▶ Press and hold the **SEL**  (up) or **SEL**  (down) button to move the menu quickly.

12:34	SETTING	0 km/h
FUNCTION	BACKGROUND	
LAP TIME	USER LETTER	TRIP B
DISPLAY	FAVORITE	TOTAL
GENERAL		TRIP A
SERVICE	DISPLAY MODE	

- 3 Press the **MODE** button. The "INFO 1" setting is set, and then the display returns to the upper level hierarchy.

## Instruments (Continued)

### INFO 2

You can select the "REV", "INST.CON.S.", "AVG.CON.S.", "TRIP A CONS.", "AVG.SPD." or "ELAPSED" for INFO 2.

- 1 Select the "INFO 2" using the **SEL** ▲ (up) or **SEL** ▼ (down) button, and press the **MODE** button.
  - ▶ Press and hold the **SEL** ▲ (up) or **SEL** ▼ (down) button to move the menu quickly.

12:34	SETTING	0 km/h
FUNCTION	BACKGROUND	
LAP TIME	USER LETTER	INFO 1
DISPLAY FAVORITE		INFO 2
GENERAL	←	INFO 3
SERVICE	DISPLAY MODE	←





- 2 Select the "REV", "INST.CON.S.", "AVG.CON.S.", "TRIP A CONS.", "AVG.SPD." or "ELAPSED" using the **SEL** ▲ (up) or **SEL** ▼ (down) button.
  - ▶ Press and hold the **SEL** ▲ (up) or **SEL** ▼ (down) button to move the menu quickly.

12:34	SETTING	0 km/h
FUNCTION	BACKGROUND	AVG.SPD.
LAP TIME	USER LETTER	ELAPSED
DISPLAY FAVORITE		REV
GENERAL	←	INST.CON.S.
SERVICE	DISPLAY MODE	AVG.CON.S.





- 3 Press the **MODE** button. The "INFO 2" setting is set, and then the display returns to the upper level hierarchy.

**INFO 3**

You can select the "CBR LOGO", "REV IND NE", "GRIP ANGLE", "VOLTAGE", "DATE", "USER LETTER" or blank display for INFO 3.

- 1 Select the "INFO 3" using the **SEL**  (up) or **SEL**  (down) button, and press the **MODE** button.
  - ▶ Press and hold the **SEL**  (up) or **SEL**  (down) button to move the menu quickly.

12:34		SETTING	0 km/h
FUNCTION	BACKGROUND		
LAP TIME	USER LETTER		INFO 2
<b>DISPLAY FAVORITE</b>			<b>INFO 3</b>
GENERAL			
SERVICE	DISPLAY MODE		INFO 1

- 2 Select the "CBR LOGO", "REV IND NE", "GRIP ANGLE", "VOLTAGE", "DATE", "USER LETTER" or blank display using the **SEL**  (up) or **SEL**  (down) button.
  - ▶ Press and hold the **SEL**  (up) or **SEL**  (down) button to move the menu quickly.

12:34		SETTING	0 km/h
FUNCTION	BACKGROUND		USER LETTER
LAP TIME	USER LETTER		
<b>DISPLAY FAVORITE</b>			<b>CBR LOGO</b>
GENERAL			REV IND NE
SERVICE	DISPLAY MODE		GRIP ANGLE

- 3 Press the **MODE** button. The "INFO 3" setting is set, and then the display returns to the upper level hierarchy.

## Instruments *(Continued)*

### GENERAL

#### To Set the GENERAL Menu

- 1 Select the "GENERAL" on the main menu screen. **➡ P.43**
- 2 Select a menu by pressing the **[SEL] ▲** (up) or **[SEL] ▼** (down) button and press the **[MODE]** button.

#### To end the setting

Select the **[↩]** (return) menu on the menu screen. The display returns to the "GENERAL" on the main menu screen.

#### "GENERAL" is selected

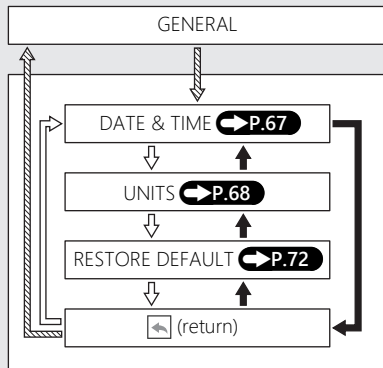



 Press the **[MODE]** button





 Press the **[SEL] ▲** (up) button



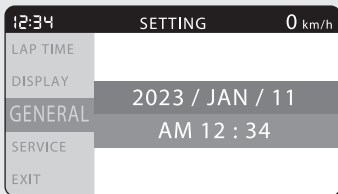





 Press the **[SEL] ▼** (down) button

## DATE & TIME

- 1 Press the **SEL**  (up) or **SEL**  (down) button until the desired tens digit of the year is displayed.
- 2 Press the **MODE** button. The cursor moves to the ones digit of the year.



- 3 Press the **SEL**  (up) or **SEL**  (down) button until the desired ones digit of the year is displayed.
- 4 Press the **MODE** button. The cursor moves to the indication of month.
- 5 Press the **SEL**  (up) or **SEL**  (down) button until the desired month is displayed.

- 6 Press the **MODE** button. The cursor moves to the indication of date.
- 7 Press the **SEL**  (up) or **SEL**  (down) button until the desired date is displayed.
- 8 Press the **MODE** button. The cursor moves to the "AM" or "PM".
- 9 Select the "AM" or "PM" using the **SEL**  (up) or **SEL**  (down) button.
- 10 Press the **MODE** button. The cursor moves to the indication of hour.
- 11 Press the **SEL**  (up) or **SEL**  (down) button until the desired hour is displayed.
- 12 Press the **MODE** button. The cursor moves to the indication of minute.
- 13 Press the **SEL**  (up) or **SEL**  (down) button until the desired minute is displayed.
- 14 Press the **MODE** button. The date and clock setting is set, and then the display returns to the upper level hierarchy.



Press and hold the **SEL**  (up) or **SEL**  (down) button to move the menu quickly.

## Instruments *(Continued)*

### UNITS

You can change the speed and mileage, and fuel mileage meter units.

#### To set each unit

- 1 Select the "SPEED" or "FUEL CONS." using the **SEL**  (up) or **SEL**  (down) button.
- 2 Press the **MODE** button. The display moves to each unit setting screen.



The units of the speedometer, odometer, tripmeter A/B, current fuel mileage, average fuel mileage, tripmeter A fuel consumption, average speed, available driving distance and

amount of remaining fuel are changed in "SPEED" menu.

The units of the current fuel mileage, average fuel mileage and amount of remaining fuel are changed in "FUEL CONS." menu.

#### To end the setting

Select the  (return) on the menu screen. The display returns to the "UNITS" menu on the "GENERAL" menu screen.



## Speed and Mileage Unit [SPEED]

- 1 Select the "km/h" or "mph" using the **[SEL]** **▲** (up) or **[SEL]** **▼** (down) button.
- 2 Press the **[MODE]** button. The speed and mileage unit setting is set, and then the display returns to the upper level hierarchy.

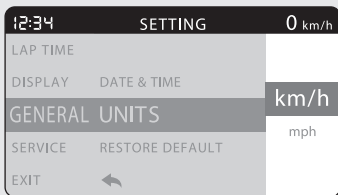

When selecting the "km/h"

- Units of the speedometer and average speed show "km/h".
- Units of the odometer, tripmeter A/B and available driving distance show "km".

- Units of the current fuel mileage and average fuel mileage show "L/100km" or "km/L".
- Units of the tripmeter A fuel consumption and amount of remaining fuel show "L".

When selecting the "mph"

- Units of the speedometer and average speed show "mph".
- Units of the odometer, tripmeter A/B and available driving distance show "mile".
- Units of the current fuel mileage and average fuel mileage show "MPG" or "mile/L".
- Units of the tripmeter A fuel consumption and amount of remaining fuel show "L" or "GAL".



## Instruments *(Continued)*

### Fuel Mileage Meter Unit [FUEL CONS.]

- 1 When the "km/h" of the "SPEED" menu is selected

Select the "L/100 km" or "km/L" using the **SEL**  (up) or **SEL**  (down) button.

When the "mph" of the "SPEED" menu is selected

Select the "MPG" or "mile/L" using the **SEL**  (up) or **SEL**  (down) button.

- 2 Press the **MODE** button. The fuel mileage meter unit setting is set, and then the display returns to the upper level hierarchy.

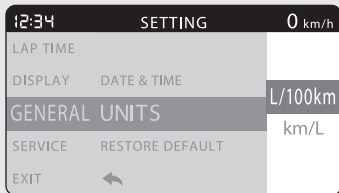

When selecting the "L/100 km"

- Units of the current fuel mileage and average fuel mileage show "L/100 km".
- Units of the tripmeter A fuel consumption and amount of remaining fuel show "L".

When selecting the "km/L"

- Units of the current fuel mileage and average fuel mileage show "km/L".
- Units of the tripmeter A fuel consumption and amount of remaining fuel show "L".

When selecting the "MPG"

- Units of the current fuel mileage and average fuel mileage show "MPG".
- Units of the tripmeter A fuel consumption and amount of remaining fuel show "GAL".



When selecting the "mile/L"

- Units of the current fuel mileage and average fuel mileage show "mile/L".
- Units of the tripmeter A fuel consumption and amount of remaining fuel show "L".

## Instruments *(Continued)*

### RESTORE DEFAULT

The set value can be returned to default setting.

- 1 Select the "NO" (not restore) or "YES" (restore) using the **SEL**  (up) or **SEL**  (down) button.



#### 2 When the "NO" is selected

Press the **MODE** button. The set value is maintained, and then the display returns to the upper level hierarchy.

#### When the "YES" is selected

Press the **MODE** button. The display changes to the confirmation screen.



- 3 Select the "NO" (not restore) or "YES" (restore) using the **SEL**  (up) or **SEL**  (down) button on the confirmation screen.

#### 4 When the "NO" is selected

Press the **MODE** button. The set value is maintained, and then the display returns to the "RESTORE DEFAULT" menu on the "GENERAL" menu screen.

#### When the "YES" is selected

Press the **MODE** button. The set value return to default setting.

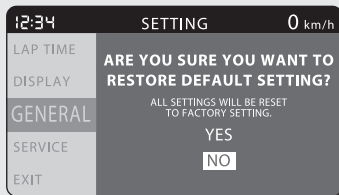

- 5 Select the "EXIT" by pressing the **MODE** button.

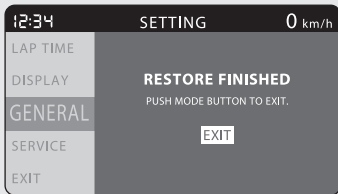

- 6 The display returns to the "RESTORE DEFAULT" menu on the "GENERAL" menu screen.

Default setting values:

- LAP DATA: Cleared
- DISPLAY MODE: STREET
- SHIFT INDICATOR: OFF
- BRIGHTNESS: AUTO
- BACK GROUND: AUTO
- USER LETTER: CBR600RR
- FAVORITE: TOTAL, REV, CBR LOGO
- SPEED UNIT: km/h
- FUEL CONS UNIT: L/100 km
- Riding mode: USER 1 and USER 2 setting value returns to initial setting values.

➔ P.94

- HISS INDICATOR: ON
- QUICK SHIFTER
  - UP: OFF
  - DOWN: OFF
  - UP LVL: 2
  - DOWN LVL: 2

## Instruments *(Continued)*

### SERVICE

#### To Set the SERVICE Menu

- 1 Select the "SERVICE" menu on the main menu screen. **➡ P.43**
- 2 Select the menu by pressing the **SEL ▲** (up) or **SEL ▼** (down) button and press the **MODE** button.

#### To end the setting

Select the **◀** (return) on the menu screen, and then the display returns to the "SERVICE" menu on the main menu screen.

#### "SERVICE" is selected

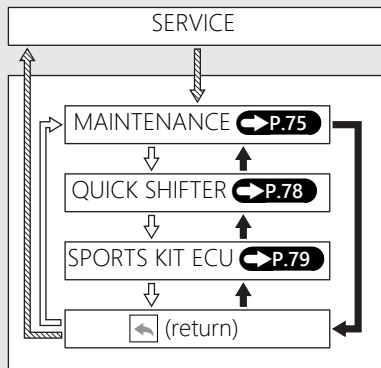

Press the **MODE** button

Press the **SEL ▲** (up) button

Press the **SEL ▼** (down) button

## MAINTENANCE

You can check the next inspection time and change the setting of next inspection.

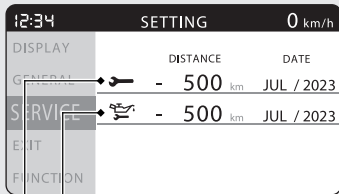

**Next engine oil change**  
**Next periodic inspection**

To return to the upper level hierarchy, press the **MODE** button.

Display range:

DISTANCE:

Next periodic inspection:

-12000 to +99900 km  
 (-8000 to +99950 mile)

Next engine oil change:

-6000 to +99980 km  
 (-4000 to +99980 mile)

▶ Pass 0 km (mile): "-" mark changed to "+" mark

DATE:

Month: JAN to DEC

Year: 2010 to 2099

## Instruments (Continued)



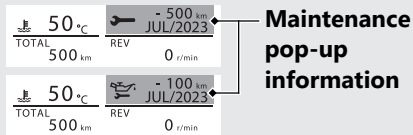

When reaching any of the following, the pop-up information is appears in the ordinary display. **➡ P.84**



- "-500 km" or "-300 mile" from the next periodic inspection
- "-100 km" or "-60 mile" from the next engine oil change
- One month before the set month









## Next inspection setting

- 1 Select “” (periodic inspection) or “” (engine oil change) using the **SEL**  (up) or **SEL**  (down) button.

12:34		SETTING		0 km/h
DISPLAY		DISTANCE	DATE	
GENERAL		- 500 km	JUL / 2023	
SERVICE		- 500 km	JUL / 2023	
EXIT				
FUNCTION				

- 2 Press and hold the **MODE** button until the “DISTANCE” value start flashing.

12:34		SETTING		0 km/h
DISPLAY		DISTANCE	DATE	
GENERAL		- 	- - - / - - -	
SERVICE		- 500 km	JUL / 2023	
EXIT				
FUNCTION				

- 3 Press the **SEL**  (up) or **SEL**  (down) button until the desired distance value is displayed.
- ▶ Available setting range of periodic inspection:  
100 to 12,000 km (100 to 8,000 mile)
  - ▶ Available setting range of engine oil change:  
100 to 12,000 km (100 to 8,000 mile)

## Instruments *(Continued)*

- 4 Press the **MODE** button. The cursor moves to the indication of month.
- 5 Press the **SEL** **▲** (up) or **SEL** **▼** (down) button until the desired month is displayed.
- 6 Press the **MODE** button. The cursor moves to the tens digit of the year.
- 7 Press the **SEL** **▲** (up) or **SEL** **▼** (down) button until the desired tens digit of the year is displayed.
- 8 Press the **MODE** button. The cursor moves to the ones digit of the year.
- 9 Press the **SEL** **▲** (up) or **SEL** **▼** (down) button until the desired ones digit of the year is displayed.
- 10 Press the **MODE** button. The mileage and date setting is set, and then the display returns to the upper level hierarchy.

## QUICK SHIFTER

“INITIALIZE” and “EQUIPMENT” are displayed but not selectable.

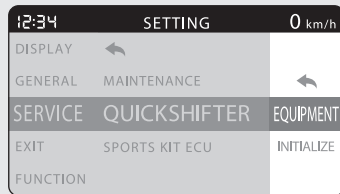

Select the **←** (return) on the menu screen, and then the display returns to the “QUICKSHIFTER” menu on the “SERVICE” menu screen.

## SPORTS KIT ECU

"SPORTS KIT ECU USAGE" is displayed but not usable.

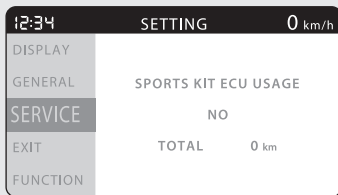

To return to the upper level hierarchy, press the **MODE** button.

## Instruments (Continued)

### Lap Timer

You can record lap time in the circuit mode.

➡P.24

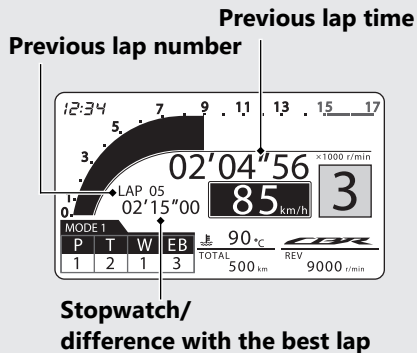

You can check and clear the recorded lap time data in the setting mode. ➡P.52

➡P.53

### Best icon

(Displayed when the fastest lap time displayed.)

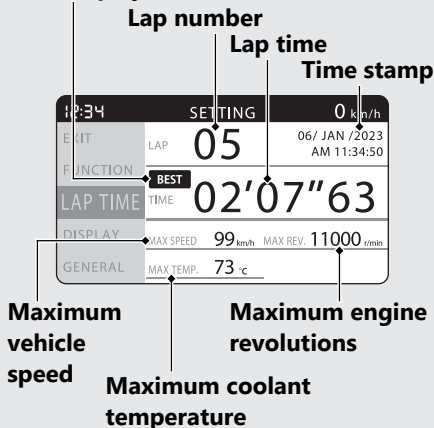

The lap time data include lap time, maximum vehicle speed, maximum engine revolutions, maximum coolant temperature, maximum acceleration, maximum deceleration, maximum left bank angle and maximum right bank angle.

Display range:

Previous lap number: 0 to 50

▶ Exceeds 50, repeats the "50"

Previous lap time: 00'00"00 to 99'59"99

▶ Exceeds 99'59"99, returns to the "00'00"00"

Stopwatch: 00'00"00 to 99'59"99

▶ Exceeds 99'59"99, returns to the "00'00"00"

Difference with the best lap:

-99'59"99 to 00'00"00 to +99'59"99

Maximum vehicle speed:

0 to 299 km/h (0 to 186 mph)

Maximum engine revolutions:

0 to 20000 r/min (rpm)

Maximum coolant temperature:

-40 to 150°C

Maximum acceleration: 0 to 3.2 G

Maximum deceleration: 0 to 3.2 G

Maximum left bank angle:

0 to 90 deg

Maximum right bank angle:

0 to 90 deg

## Instruments (Continued)

### To Measure the Lap Time

- 1 Press and hold the **LAP** button or select the "CIRCUIT" menu on the "DISPLAY MODE" menu screen. **➡P.24** **➡P.55** **➡P.56**
- 2 To start measurement, press the **LAP** button.
  - ▶ The stopwatch starts measurement.

#### Stopwatch

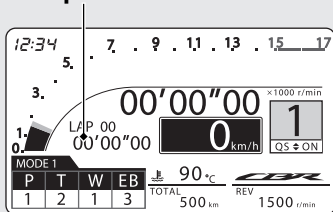

- 3 To record lap time, press the **LAP** button at each lap.
  - ▶ The stopwatch changes to display of the difference with the best lap. After 10 seconds, the display will return to the stopwatch.
  - ▶ The previous lap time and previous lap number change to the information of the previous lap.
  - ▶ If you press the **LAP** button again within two seconds, lap time is not recorded.
  - ▶ When exceeds 50 lap, the previous lap number repeats the "LAP 50".

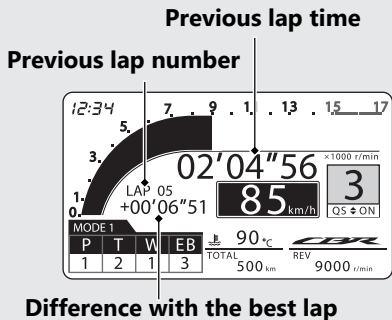

- 4 To end measurement, press and hold the **LAP** button.

### To restart the measurement

Press the **LAP** button again. The stopwatch restarts measurement.

- ▶ Measurement starts from the next lap.

### To Check or Clear the Lap Time

Select the "LAP TIME" menu in the setting mode. **➡P.52** **➡P.54**

## Instruments (Continued)

### Pop-up information

In the following case, the INFO 3 display or the INFO 3 display and coolant temperature gauge change to a pop-up information display.

- Maintenance information:  
When the inspection time of your vehicle is approaching.
- Helpful information:  
When your vehicle has helpful information.
- Failure information:  
When your vehicle has a problem with the PGM-FI system.

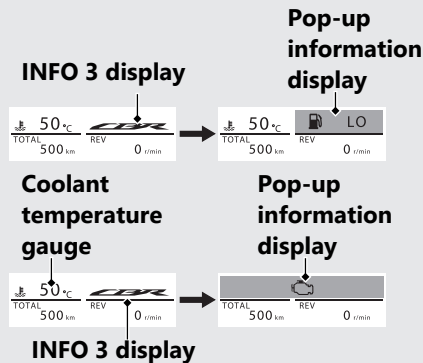

When your vehicle has multiple pieces of information, each pop-up information display appears alternately.

If your vehicle has a problem with the PGM-FI, the failure information is displayed in priority to other information.









## Maintenance Information

Indication	Explanation	Remedy
 - 500 km JUL/2023	When the periodic inspection time of your vehicle is approaching.	Have your vehicle inspected by your dealer.
 - 100 km JUL/2023	When the oil change time of your vehicle is approaching.	Change the engine oil.

## Helpful Information

Indication	Explanation	Remedy
 SIDE STAND	When the side stand is down.	Raise the side stand.
 LO	When remaining fuel is reached 4.0 L (1.1 US gal, 0.9 Imp gal).	Fill the fuel tank.  <b>P.105</b>

## Failure Information

Indication	Explanation	Remedy
	When your vehicle has a problem with the PGM-FI system.	Reduce speed and have your vehicle inspected by your dealer as soon as possible.

# Indicators

If one of these indicators does not come on when it should, have your dealer check for problems.

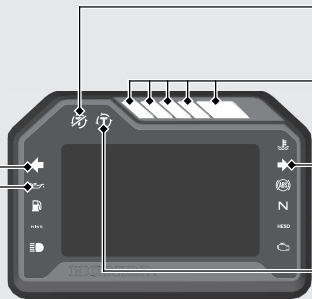

## **Torque Control OFF indicator**

Comes on when the Torque Control is turned off.

## **Shift indicators** **P.89**

Comes on briefly when the ignition switch is turned to the **I** (On) position.

## **Right turn signal indicator**

## **Torque Control indicator**

- Comes on when the ignition switch is turned to the **I** (On) position. Goes off when your speed reaches approximately 5 km/h (3 mph) to indicate Torque Control is ready to work.
- Blinks when Torque Control is operating.

**If it comes on while riding:**  **P.160**

## **Low oil pressure indicator**

Comes on when the ignition switch is turned to the **I** (On) position. Goes off when the engine starts.

**If it comes on while engine is running:**  **P.157**

## **Left turn signal indicator**

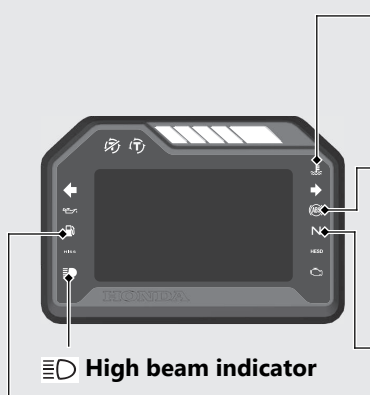

 **High beam indicator**

### **Low fuel indicator**

- Comes on briefly when the ignition switch is turned to the **I** (On) position.
- Comes on when there is only reserve fuel left in the fuel tank. Remaining fuel when low fuel indicator comes on: 4.0 L (1.1 US gal, 0.9 Imp gal)

**If it comes on:**  **P.38**

### **High coolant temperature indicator**

Comes on briefly when the ignition switch is turned to the **I** (On) position.

**If it comes on while riding:**  **P.156**

### **ABS (Anti-lock Brake System) indicator**

Comes on when the ignition switch is turned to the **I** (On) position. Goes off when your speed reaches approximately 10 km/h (6 mph).

**If it comes on while riding:**  **P.159**

### **Neutral indicator**

Comes on when the transmission is in Neutral.

## Indicators (Continued)



### HISS indicator ➡ P.155

- Comes on briefly when the ignition switch is turned to the **I** (On) position. Goes off if the ignition key has the correct coding.
- Flashes every 2 seconds for 24 hours when the ignition switch is turned to the **O** (Off) position.

### HESD (Honda Electronic Steering Damper) indicator

Comes on briefly when the ignition switch is turned to the **I** (On) position.

**If it comes on while engine is running:**

➡ P.159

### PGM-FI (Programmed Fuel Injection) malfunction indicator lamp (MIL)

Comes on briefly when the ignition switch is turned to the **I** (On) position.

GS type

**If it comes on while engine is running:**

➡ P.158

ED, II ED type

**If it comes on or blinks while engine is running:** ➡ P.158

## Shift Indicators

The shift indicators light or blink by the engine revolutions. The first indicator lights when the engine revolutions reach a number 800 r/min (rpm) below a preset revolution number.

The second, third and fourth indicators will light each time the engine revolutions is 200 r/min (rpm) rise.

All indicators will blink when engine revolutions is reached the set value.

## Setting of the Shift Indicators







You can change the engine revolutions at which the shift indicators start blinking.

Initial setting: OFF

Available setting range:

4,000 - 17,500 r/min (rpm)

Example set value: 11,600 r/min (rpm)

	0 to 10,800 r/min (rpm) All indicators go off
	10,800 r/min (rpm) First indicator comes on
	11,000 r/min (rpm) Second indicator comes on
	11,200 r/min (rpm) Third indicator comes on
	11,400 r/min (rpm) Fourth indicator comes on
	11,600 r/min (rpm) All indicators blink

# Switches

## LAP button

Operate the lap timer



## Horn button



## Turn signal switch

▶ Pressing the switch turns the turn signal off.



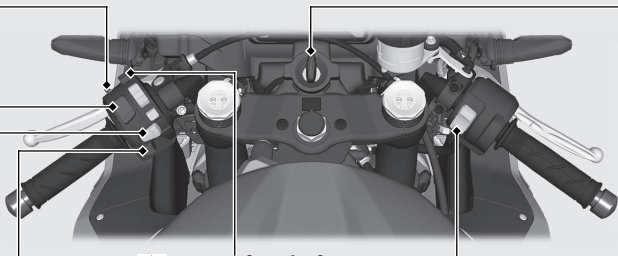

## Hazard switch

Switchable when the ignition switch is in the **I** (On) position.



## Headlight dimmer switch/Passing light control switch

-  : High beam
-  : Low beam
-  : Flashes the high beam headlight.

## Ignition switch

Switches the electrical system on/off, locks the steering.

- ▶ Key can be removed when in the ○ (Off) or  (Lock) position.

## Engine stop switch/ Start button

Should normally remain in the  (Run) position.

- ▶ In an emergency, switch to the  (Stop) position to stop the engine.

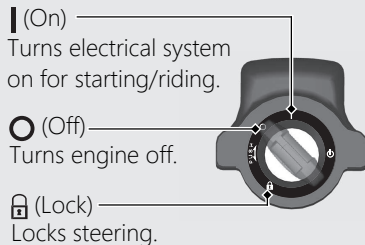

## Switches *(Continued)*

### Steering Lock

Lock the steering when parking to help prevent theft.

A U-shaped wheel lock or similar device is also recommended.

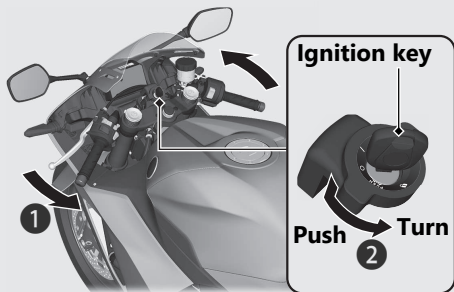

### Locking

- 1 Turn the handlebars all the way to the left.
- 2 Push the key down, and turn the ignition switch to the  (Lock) position.
  - ▶ Jiggle the handlebars if the lock is difficult to engage.
- 3 Remove the key.

### Unlocking

Insert the key, push it in, and turn the ignition switch to the  (Off) position.



# Riding mode

You can change the riding mode.  
The riding mode consists of the following parameters.

P: Engine output level

T: Torque control level

W: Wheelie control level

EB: Engine brake level

When “-” is displayed, go to your dealer for service.

## Current riding mode

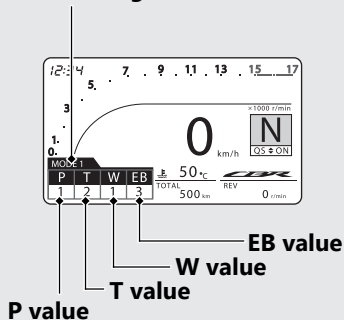

## Riding mode *(Continued)*

Riding mode has five modes.

Available riding mode: MODE 1, MODE 2, MODE 3, USER 1 and USER 2.

### MODE 1, MODE 2 and MODE 3

- ▶ MODE 1 is suitable for track riding.
- ▶ MODE 2 is suitable for winding roads.
- ▶ MODE 3 is suitable for street riding.

Each value can not be changed.

### USER 1 and USER 2

Each value can be changed.

### Initial setting

Riding modes	P value	T value	W value	EB value
MODE 1	1	2	1	3
MODE 2	2	5	2	3
MODE 3	5	8	3	1
USER 1	1 <sup>*1</sup>	5 <sup>*1</sup>	2 <sup>*1</sup>	1 <sup>*1</sup>
USER 2	2 <sup>*1</sup>	5 <sup>*1</sup>	2 <sup>*1</sup>	2 <sup>*1</sup>

Notes:

\*1 : Value can be changed

**P value (Engine output level)**

P value has five setting levels.

Available setting range: 1 to 5

- ▶ Level 1 has the most power.
- ▶ Level 5 has the least power.

**T value (Torque control level)**

T value has ten setting levels.

Available setting range: 0 to 9

- ▶ Level 1 is the minimum Torque Control level.
- ▶ Level 9 is the maximum Torque Control level.
- ▶ Level 0 deactivates the Torque Control.
- ▶ When the T value is set to 0, the W value automatically changes 0.

**W value (Wheelie control level)**

W value has four setting levels.

Available setting range: 1 to 3

- ▶ Level 1 is the minimum Wheelie Control level.
- ▶ Level 3 is the maximum Wheelie Control level.
- ▶ Level 0 deactivates the Wheelie Control.

**EB value (Engine brake level)**





EB value has three setting levels.



Available setting range: 1 to 3

- ▶ Level 1 has the strongest engine braking effect.
- ▶ Level 3 has the weakest engine braking effect.

## Riding mode *(Continued)*

### Selecting the riding mode

- 1 Stop the vehicle.
- 2 Select the riding mode display.  P.27
- 3 Press the   (up) or   (down) button with the throttle fully closed.

  (up) button

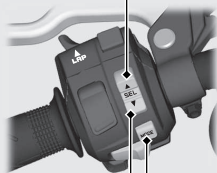

  (down) button

 button

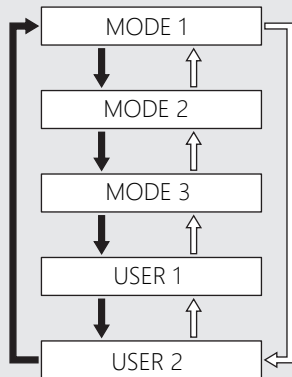

 Press the   (up) button

 Press the   (down) button

## Setting the riding mode

You can change the P, T, W and EB values on the USER 1 and USER 2 of the riding mode.







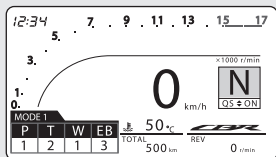

- 1 Stop the vehicle.
- 2 Select the USER 1 or USER 2 in the riding mode you want to set. **➡ P.94**
- 3 Press and hold the **MODE** button until P value is selected.
- 4 Press the **SEL ▲** (up) or **SEL ▼** (down) button until the desired value is displayed.
- 5 Press the **MODE** button until T value is selected.
- 6 Press the **SEL ▲** (up) or **SEL ▼** (down) button until the desired value is displayed.
  - ▶ T value can be changed to level 0 by pressing and holding the **SEL ▼** (down) button at the time of level 1.
- 7 Press the **MODE** button until W value is selected.

- 8 Press the **SEL ▲** (up) or **SEL ▼** (down) button until the desired value is displayed.
- 9 Press the **MODE** button until EB value is selected.
- 10 Press the **SEL ▲** (up) or **SEL ▼** (down) button until the desired value is displayed.
- 11 Press and hold the **MODE** button until ordinary display is displayed.

You can stop setting the riding modes at any time by pressing and holding the **MODE** button.

## Riding mode (Continued)





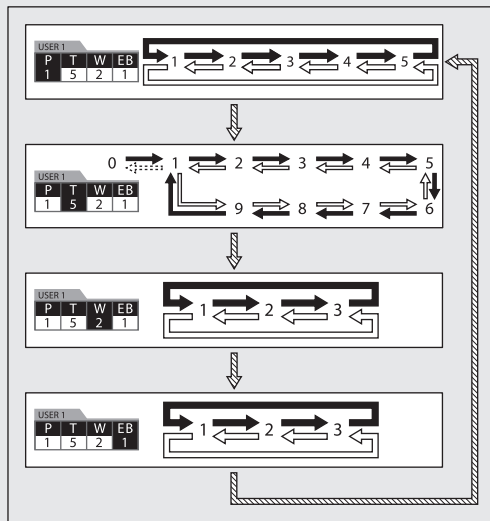

-  Press the **MODE** button
-  Press and hold the **MODE** button
-  Press the **SEL**  (up) button
-  Press the **SEL**  (down) button
-  Press and hold the **SEL**  (down) button

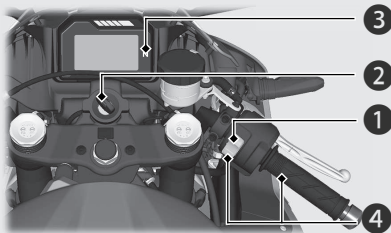

# Starting the Engine

Start your engine using the following procedure, regardless of whether the engine is cold or warm.



- 1 Make sure the engine stop switch is in the  (Run) position.
- 2 Turn the ignition switch to the  (On) position.
- 3 Shift the transmission to Neutral ( indicator comes on). Alternatively, pull in the clutch lever to start your vehicle with the transmission in gear so long as the side stand is raised.
- 4 Press the start button with the throttle completely closed.

## NOTICE

- If the engine does not start within 5 seconds, turn the ignition switch to the  (Off) position and wait 10 seconds before trying to start the engine again to recover battery voltage.
- Extended fast idling and revving the engine can damage the engine and the exhaust system.
- Snapping the throttle or fast idling for more than about 5 minutes may cause exhaust pipe discolouration.

## Starting the Engine *(Continued)*

### If you cannot start the engine:

With the throttle slightly open (about 3 mm (0.1 in), without freeplay) while starting the engine.

### About 3 mm (0.1 in), without freeplay

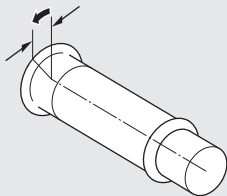

### If the engine does not start:

- ① Open the throttle fully and press the start button for 5 seconds.
  - ▶ The engine will not start at this time. (When the throttle is fully open, the engine will not start when the start button is pressed.)  
Release the throttle and start button after 5 seconds and proceed to step ②.
- ② Repeat the normal starting procedure.
- ③ If the engine starts, open the throttle slightly if idling is unstable.
- ④ If the engine does not start, wait 10 seconds before trying steps ① & ② again.

**If Engine Will Not Start** ➡ P.155



# Shifting Gears

Your vehicle transmission has 6 forward gears in a one-down, five-up shift pattern.

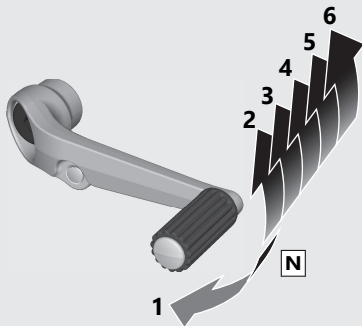

If you put the vehicle in gear with the side stand down, the engine will shut off.

## Shifting Gears *(Continued)*

### Quick Shifter

This system enables very quick up and down shifting without clutch and throttle operations.

- ▶ This system does not function when upshifting with the throttle closed.
  - ▶ This system functions when the engine speed is more than 1,800 r/min (rpm) on upshifting or more than the idle speed on downshifting.
  - ▶ This system does not function when the clutch lever is being operated.
- If "-" is displayed on the gear position indicator, the Quick Shifter system does not operate.
  - If the Quick Shifter does not operate normally, the clutch can be used to complete the shift operation.

- The Quick Shifter can be individually turned ON (active) and OFF (deactivate), also the shift pedal load level for activating the Quick Shifter can be adjusted during up and down shifting.
- If the PGM-FI malfunction indicator lamp comes on or the gear position indicator flashes "-" in the current gear position, the Quick Shifter system may not operate. If either of the above occurs, contact your dealer as soon as possible.

### **To Change the Setting of Quick Shifter**

**➔ P.46**

# Emergency Stop Signal

Emergency stop signal activates when the system detects hard braking about 50 km/h (31 mph) or above to alert drivers behind you about sudden braking by rapidly flashing both turn signal lights. This may help to alert drivers behind you to take appropriate means to avoid a possible collision with your vehicle.

The emergency stop signal stops operating when:

- You release the brakes.
- The ABS is deactivated.
- Your vehicle's decelerating speed becomes moderate.
- You press the hazard switch.

## When the system activates:

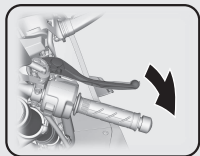

**1 Hard braking**

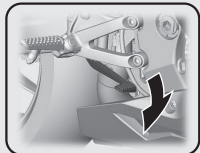

**2 Both turn signal indicators blink**

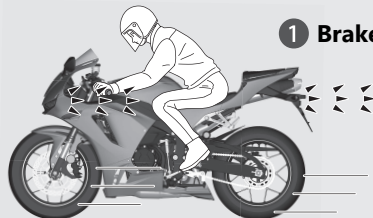

**1 Brakelight comes on**

**2 Both turn signals flash**

## **Emergency Stop Signal** *(Continued)*

- ▶ The emergency stop signal is not a system that can prevent a possible rear-end collision caused by your hard braking. It is always recommended to avoid hard braking unless it is absolutely necessary.
- ▶ The emergency stop signal does not activate with the hazard switch pressed in.
- ▶ If the ABS stops working for a certain period during braking, the emergency stop signal may not activate at all.

# Refuelling

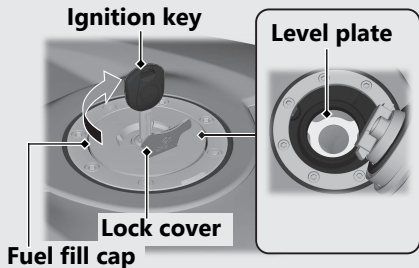

Do not fill with fuel above the level plate.

**Fuel type:** Unleaded petrol only

**Fuel octane number:** Your vehicle is designed to use Research Octane Number (RON) 95 or higher.

**Tank capacity:** 18 L (4.8 US gal, 4.0 Imp gal)

**Refuelling and Fuel Guidelines** ➔ P.16

## Opening the Fuel Fill Cap

Open the lock cover, insert the ignition key, and turn it clockwise to open the fuel fill cap.

## Closing the Fuel Fill Cap

- 1 After refuelling, push the fuel fill cap closed until it locks.
- 2 Remove the ignition key and close the lock cover.
  - ▶ The ignition key cannot be removed if the fuel fill cap is not locked.

## **⚠ WARNING**

Petrol is highly flammable and explosive. You can be burned or seriously injured when handling fuel.

- Stop the engine, and keep heat, sparks, and flames away.
- Only handle fuel outdoors.
- Wipe up spills immediately.

# Storage Equipment

## Helmet Holders

The helmet holders and helmet set wire (in the tool kit) are located under the rear seat.

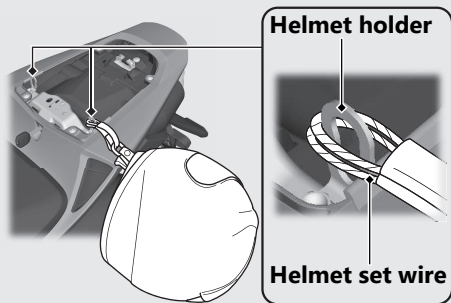

► Use the helmet holder only when parked.

**Removing the Rear Seat** ➔ P.132

## **⚠ WARNING**

Riding with a helmet attached to the holder can interfere with your ability to safely operate the vehicle and could lead to a crash in which you can be seriously hurt or killed.

Use the helmet holder only while parked. Do not ride with a helmet secured by the holder.

## Tool Kit/Document Bag

The tool kit and document bag are located under the rear seat.

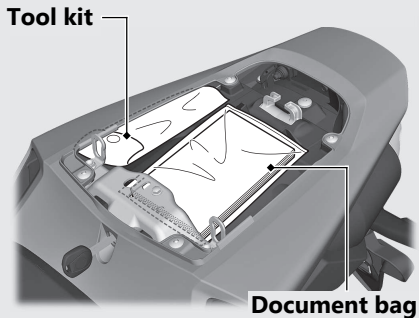

Removing the Rear Seat → P.132

# Maintenance

Please read "Importance of Maintenance" and "Maintenance Fundamentals" carefully before attempting any maintenance. Refer to "Specifications" for service data.

<b>Importance of Maintenance</b> .....	P. 109	<b>Side Stand</b> .....	P. 140
<b>Maintenance Schedule</b> .....	P. 110	<b>Drive Chain</b> .....	P. 141
<b>Maintenance Fundamentals</b> .....	P. 115	<b>Clutch</b> .....	P. 143
<b>Tools</b> .....	P. 126	<b>Throttle</b> .....	P. 146
<b>Removing &amp; Installing Body</b>		<b>Other Adjustments</b> .....	P. 147
<b>Components</b> .....	P. 127	Adjusting the Brake Lever .....	P. 147
Battery .....	P. 127	Adjusting the Front Suspension .....	P. 148
Clip.....	P. 128	Adjusting the Rear Suspension.....	P. 151
Front Seat.....	P. 129		
Right Middle Cowl.....	P. 130		
Rear Seat .....	P. 132		
<b>Engine Oil</b> .....	P. 133		
<b>Coolant</b> .....	P. 135		
<b>Brakes</b> .....	P. 137		



# Importance of Maintenance

## Importance of Maintenance

Keeping your vehicle well-maintained is absolutely essential to your safety and to protect your investment, obtain maximum performance, avoid breakdowns, and reduce air pollution. Maintenance is the owner's responsibility. Be sure to inspect your vehicle before each ride and perform the periodic checks specified in the Maintenance Schedule.

➔ P. 110

### **⚠ WARNING**

Improperly maintaining your vehicle or failing to correct a problem before you ride can cause a crash in which you can be seriously hurt or killed.

Always follow the inspection and maintenance recommendations and schedules in this owner's manual.

## Maintenance Safety

Always read the maintenance instructions before you begin each task and make sure that you have the tools, parts, and skills required. We cannot warn you of every conceivable hazard that can arise in performing maintenance. Only you can decide whether or not you should perform a given task.

Follow these guidelines when performing maintenance.

- Stop the engine and remove the key.
- Place your vehicle on a firm, level surface using the side stand or a maintenance stand to provide support.
- Allow the engine, muffler, brakes, and other high-temperature parts to cool before servicing as you can get burned.
- Run the engine only when instructed, and do so in a well-ventilated area.

# Maintenance Schedule

The maintenance schedule specifies the maintenance requirements necessary to ensure safe, dependable performance, and proper emission control.











Maintenance work should be performed in accordance with Honda's standards and specifications by properly trained and equipped technicians. Your dealer meets all of these requirements. Keep an accurate record of maintenance to help ensure that your vehicle is properly maintained.

Make sure that whomever performs the maintenance completes this record.



All scheduled maintenance is considered a normal owner operating cost and will be charged to you by your dealer. Retain all receipts. If you sell the vehicle, these receipts should be transferred with the vehicle to the new owner.

Honda recommends that your dealer should road test your vehicle after each periodic maintenance is carried out.

## ED, II ED type

Items	Pre-ride Check P. 115	Frequency*1						Annual Check	Regular Replace	Refer to page
		× 1,000 km	1	12	24	36	48			
		× 1,000 mi	0.6	8	16	24	32			
Honda Diagnostic System			I	I	I	I	I			–
Fuel Line				I	I	I	I	I		–
Fuel Level		I								105
Throttle Operation		I		I	I	I	I	I		146
Air Cleaner *2					I		I			–
Spark Plug					I		R			–
Valve Clearance							I			–
Engine Oil		I	R	R	R	R	R	R		–
Engine Oil Filter			R		R		R			–
Engine Idle Speed				I	I	I	I	I		–
Radiator Coolant *3		I		I	I	I	I	I	3 Years	135
Cooling System				I	I	I	I	I		–
Secondary Air Supply System					I		I			–
Evaporative Emission Control System					I		I			–

**Maintenance Level**

-  : Intermediate. We recommend service by your dealer, unless you have the necessary tools and are mechanically skilled. Procedures are provided in an official Honda Shop Manual.
-  : Technical. In the interest of safety, have your vehicle serviced by your dealer.

**Maintenance Legend**

- I** : Inspect (clean, adjust, lubricate, or replace, if necessary)
- R** : Replace
- L** : Lubricate

## Maintenance Schedule

Items	Pre-ride Check P. 115	Frequency*1						Annual Check	Regular Replace	Refer to page
		× 1,000 km	1	12	24	36	48			
		× 1,000 mi	0.6	8	16	24	32			
Drive Chain	I	Every 1,000 km (600 mi): I L								141
Drive Chain Slider				I	I	I	I			142
Brake Fluid *3	I			I	I	I	I	I	2 Years	137
Brake Pads Wear	I			I	I	I	I	I		138
Brake System				I	I	I	I	I		115
Brakelight Switch				I	I	I	I	I		139
Headlight Aim				I	I	I	I	I		–
Lights/Horn	I									–
Engine Stop Switch	I									–
Clutch System	I			I	I	I	I	I		143
Side Stand	I			I	I	I	I	I		140
Suspension				I	I	I	I	I		148
Nuts, Bolts, Fasteners				I	I	I	I	I		–
Wheels/Tyres		I		I	I	I	I	I		123
Steering Head Bearings				I	I	I	I	I		–

### Notes:

\*1 : At higher odometer readings, repeat at the frequency interval established here.

\*2 : Service more frequently when riding in unusually wet or dusty areas.

\*3 : Replacement requires mechanical skill.

## GS type

Items	Pre-ride Check P. 115	Frequency*1								Annual Check	Regular Replace	Refer to page	
		× 1,000 km	1	6	12	18	24	30	36				
		× 1,000 mi	0.6	4	8	12	16	20	24				
Honda Diagnostic System	✂		I	I	I	I	I	I	I			–	
Fuel Line	✂				I		I		I	I		–	
Fuel Level		I										105	
Throttle Operation	✂	I			I		I		I	I		146	
Air Cleaner *2	✂					R			R			–	
Spark Plug	✂		Every 24,000 km (16,000 mi): I Every 48,000 km (32,000 mi): R										–
Valve Clearance	✂								I			–	
Engine Oil		I	R		R		R		R	R		–	
Engine Oil Filter			R				R					–	
Engine Idle Speed	✂				I		I		I	I		–	
Radiator Coolant *3		I			I		I		I	I	3 Years	135	
Cooling System	✂				I		I		I	I		–	
Secondary Air Supply System	✂						I					–	
Evaporative Emission Control System	✂						I					–	

## Maintenance Level

- ✂ : Intermediate. We recommend service by your dealer, unless you have the necessary tools and are mechanically skilled. Procedures are provided in an official Honda Shop Manual.
- ✂ : Technical. In the interest of safety, have your vehicle serviced by your dealer.

## Maintenance Legend

- I : Inspect (clean, adjust, lubricate, or replace, if necessary)
- R : Replace
- L : Lubricate

## Maintenance Schedule

Items	Pre-ride Check ☑ P. 115	Frequency*1								Annual Check	Regular Replace	Refer to page
		× 1,000 km	1	6	12	18	24	30	36			
		× 1,000 mi	0.6	4	8	12	16	20	24			
Drive Chain	I	Every 1,000 km (600 mi): I L										141
Drive Chain Slider				I		I		I				142
Brake Fluid *3	I			I	I	I	I	I	I	I	2 Years	137
Brake Pads Wear	I			I	I	I	I	I	I	I		138
Brake System				I		I		I		I		115
Brakelight Switch				I		I		I		I		139
Headlight Aim				I		I		I		I		–
Lights/Horn	I											–
Engine Stop Switch	I											–
Clutch System	I			I	I	I	I	I	I	I		143
Side Stand	I			I		I		I		I		140
Suspension	↗			I		I		I		I		148
Nuts, Bolts, Fasteners	↗			I		I		I		I		–
Wheels/Tyres	✂	I		I		I		I		I		123
Steering Head Bearings	✂			I		I		I		I		–

### Notes:

\*1 : At higher odometer readings, repeat at the frequency interval established here.

\*2 : Service more frequently when riding in unusually wet or dusty areas.

\*3 : Replacement requires mechanical skill.

## Pre-ride Inspection

To ensure safety, it is your responsibility to perform a pre-ride inspection and make sure that any problem you find is corrected. A pre-ride inspection is a must, not only for safety, but because having a breakdown, or even a flat tyre, can be a major inconvenience.

Check the following items before you get on your vehicle:

- Fuel level - Fill fuel tank when necessary ➤ P. 105
- Throttle - Check for smooth opening and full closing in all steering positions ➤ P. 146
- Engine oil level - Add engine oil if necessary. Check for leaks ➤ P. 133
- Coolant level - Add coolant if required. Check for leaks ➤ P. 135

- Drive chain - Check condition and slack, adjust and lubricate if necessary ➤ P. 141
- Brakes - Check operation;  
Front and Rear: check brake fluid level and pads wear ➤ P. 137, ➤ P. 138
- Lights and horn - Check that lights, indicators and horn function properly
- Engine stop switch - Check for proper function ➤ P. 90
- Clutch - Check operation;  
Adjust freeplay if necessary ➤ P. 143
- Side stand ignition cut-off system - Check for proper function ➤ P. 140
- Wheels and tyres - Check condition, air pressure and adjust if necessary ➤ P. 123

### Replacing Parts

Always use Honda Genuine Parts or their equivalents to ensure reliability and safety.

#### ED, II ED type

When ordering coloured components, specify the model name, colour, and code mentioned on the colour label.

The colour label is attached to the rear fender under the rear seat. ➤ P. 132

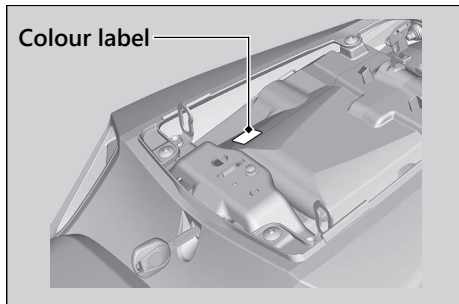

### **⚠️ WARNING**

Installing non-Honda parts may make your vehicle unsafe and cause a crash in which you can be seriously hurt or killed.

Always use Honda Genuine Parts or equivalents that have been designed and approved for your vehicle.



## Battery

Your vehicle has a maintenance-free type battery. You do not have to check the battery electrolyte level or add distilled water. Clean the battery terminals if they become dirty or corroded.

Do not remove the battery cap seals. There is no need to remove the cap when charging.

### NOTICE

Your battery is a maintenance-free type and can be permanently damaged if the cap strip is removed.



This symbol on the battery means that this product must not be treated as household waste.

### NOTICE

An improperly disposed of battery can be harmful to the environment and human health. Always confirm local regulations for proper battery disposal instruction.

## What to do in an emergency

If any of the following occur, immediately see your doctor.

- Electrolyte splashes into your eyes:
  - ▶ Wash your eyes repeatedly with cool water for at least 15 minutes. Using water under pressure can damage your eyes.
- Electrolyte splashes onto your skin:
  - ▶ Remove affected clothing and wash your skin thoroughly using water.

- Electrolyte splashes into your mouth:
  - ▶ Rinse mouth thoroughly with water, and do not swallow.

### **⚠ WARNING**

The battery gives off explosive hydrogen gas during normal operation.

A spark or flame can cause the battery to explode with enough force to kill or seriously hurt you.

Wear protective clothing and a face shield, or have a skilled mechanic do the battery servicing.

### **| Cleaning the Battery Terminals**

1. Remove the battery. **▶ P. 127**
2. If the terminals are starting to corrode and are coated with a white substance, wash with warm water and wipe clean.

3. If the terminals are heavily corroded, clean and polish the terminals with a wire brush or sandpaper. Wear safety glasses.

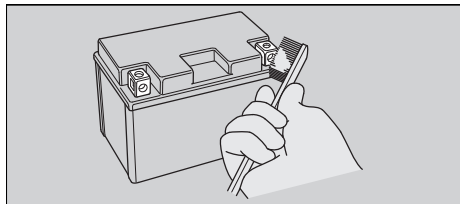

4. After cleaning, reinstall the battery.

The battery has a limited life span. Consult your dealer about when you should replace the battery. Always replace the battery with another maintenance-free battery of the same type.

### **NOTICE**

Installing non-Honda electrical accessories can overload the electrical system, discharging the battery and possibly damaging the system.

## Fuses

Fuses protect the electrical circuits on your vehicle. If something electrical on your vehicle stops working, check for and replace any blown fuses. ➤ P. 164

### Inspecting and Replacing Fuses

Turn the ignition switch to the **O** (Off) position to remove and inspect fuses. If a fuse is blown, replace with a fuse of the same rating. For fuse ratings, see "Specifications." ➤ P. 183

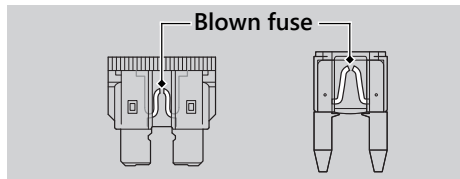

#### NOTICE

Replacing a fuse with one that has a higher rating greatly increases the chance of damage to the electrical system.

If a fuse fails repeatedly, you likely have an electrical fault. Have your vehicle inspected by your dealer.

## Engine Oil

Engine oil consumption varies and oil quality deteriorates according to riding conditions and time elapsed.

Check the engine oil level regularly, and add the recommended engine oil if necessary. Dirty oil or old oil should be changed as soon as possible.

### Selecting the Engine Oil

For recommended engine oil, see "Specifications." ➤ P. 182

If you use non-Honda engine oil, check the label to make sure that the oil satisfies all of the following standards:

- JASO T 903 standard\*1: MA
- SAE standard\*2: 10W-30
- API classification\*3: SJ or higher

## Maintenance Fundamentals

- \*1. The JASO T 903 standard is an index for engine oils for 4-stroke motorcycle engines. There are two classes: MA and MB. For example, the following label shows the MA classification.

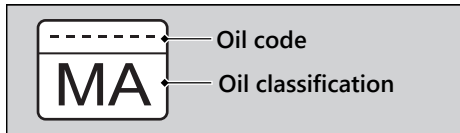

- \*2. The SAE standard grades oils by their viscosity.
- \*3. The API classification specifies the quality and performance rating of engine oils. Use SJ or higher oils, excluding oils marked as "Energy Conserving" or "Resource Conserving" on the circular API service symbol.

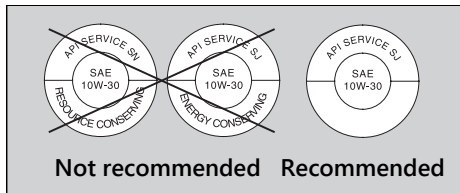

## Brake Fluid

Do not add or replace brake fluid, except in an emergency. Use only fresh brake fluid from a sealed container. If you do add fluid, have the brake system serviced by your dealer as soon as possible.

### NOTICE

Brake fluid can damage plastic and painted surfaces. Wipe up spills immediately and wash thoroughly.

### Recommended brake fluid:

Honda DOT 4 Brake Fluid or equivalent

## Drive Chain

The drive chain must be inspected and lubricated regularly. Inspect the chain more frequently if you often ride on bad roads, ride at high speed, or ride with repeated fast acceleration. ➤ P. 141

If the chain does not move smoothly, makes strange noises, has damaged rollers, has loose pins, has missing O-rings, or has kinks, have the chain inspected by your dealer.

Also inspect the drive sprocket and driven sprocket. If either has worn or damaged teeth, have the sprocket replaced by your dealer.

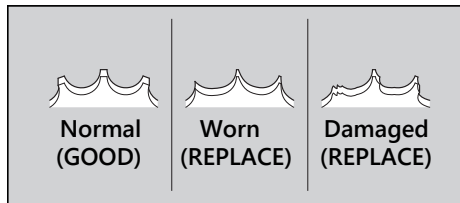

#### NOTICE

Use of a new chain with worn sprockets will cause rapid chain wear.

## Cleaning and Lubricating

After inspecting the slack, clean the chain and sprockets while rotating the rear wheel. Use a dry cloth with chain cleaner designed specifically for O-ring chains, or neutral detergent. Use a soft brush if the chain is dirty.

After cleaning, wipe dry and lubricate with the recommended lubricant.

### Recommended lubricant:

Drive chain lubricant designed specifically for O-ring chains  
If not available, use SAE 80 or 90 gear oil.

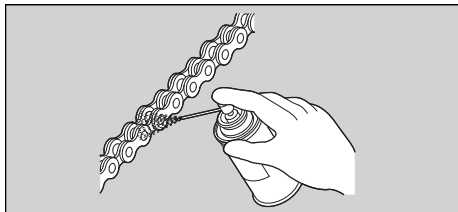

## Maintenance Fundamentals

Do not use a steam cleaner, a high pressure cleaner, a wire brush, volatile solvent such as petrol and benzene, abrasive cleaner, chain cleaner or lubricant NOT designed specifically for O-ring chains as these can damage the rubber O-ring seals.

Avoid getting lubricant on the brakes or tyres.

Avoid applying excess chain lubricant to prevent spray onto your clothes and the vehicle.

### Recommended Coolant

Pro Honda HP Coolant is a pre-mixed solution of antifreeze and distilled water.

#### Concentration:

50% antifreeze and 50% distilled water

A concentration of antifreeze below 40% will not provide proper corrosion and cold temperature protection.

A concentration of up to 60% will provide better protection in colder climates.

#### NOTICE

Using coolant not specified for aluminium engines or tap/mineral water can cause corrosion.

## Tyres (Inspecting/Replacing)

### Checking the Air Pressure

Visually inspect your tyres and use an air pressure gauge to measure the air pressure at least once a month or any time you think the tyres look low. Always check air pressure when your tyres are cold.

### Inspecting for Damage

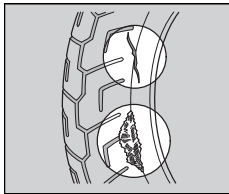

Inspect the tyres for cuts, slits, or cracks that expose fabric or cords, or nails or other foreign objects embedded in the side of the tyre or the tread.

Also inspect for any unusual bumps or bulges in the side walls of the tyres.

### Inspecting for Abnormal Wear

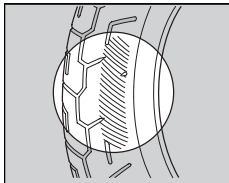

Inspect the tyres for signs of abnormal wear on the contact surface.

### Inspecting Tread Depth

Inspect the tread wear indicators. If they become visible, replace the tyres immediately. For safe riding, you should replace the tyres when the minimum tread depth is reached.

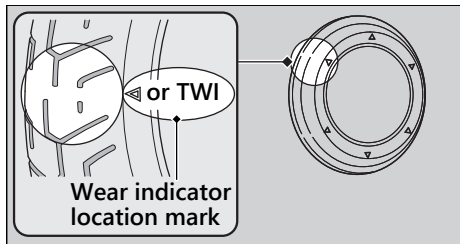

### **⚠️ WARNING**

Riding on tyres that are excessively worn or improperly inflated can cause a crash in which you can be seriously hurt or killed.

Follow all instructions in this owner's manual regarding tyre inflation and maintenance.



Have your tyres replaced by your dealer. For recommended tyres, air pressure, and minimum tread depth, see "Specifications."

➤ P. 182

Follow these guidelines whenever you replace tyres:

- Use the recommended tyres or their equivalents of the same size, construction, speed rating, and load range.
- Have the wheel balanced with Honda Genuine balance weights or equivalent after the tyre is installed.
- Do not install a tube inside a tubeless tyre on this vehicle. Excessive heat build-up can cause the tube to burst.
- Use only tubeless tyres on this vehicle. The rims are designed for tubeless tyres, and during hard acceleration or braking, a tube-type tyre could slip on the rim and cause the tyre to rapidly deflate.

## **WARNING**

Installing improper tyres on your vehicle can adversely affect handling and stability, and can cause a crash in which you can be seriously hurt or killed.

Always use the size and type of tyres recommended in this owner's manual.

# Tools

The tool kit is located under the rear seat.

➔ P. 107

You can perform some roadside repairs, minor adjustments and parts replacement with the provided tools.

- 5 mm Hex wrench
- 3 mm Hex wrench
- Fuse puller
- Helmet set wire

## Battery

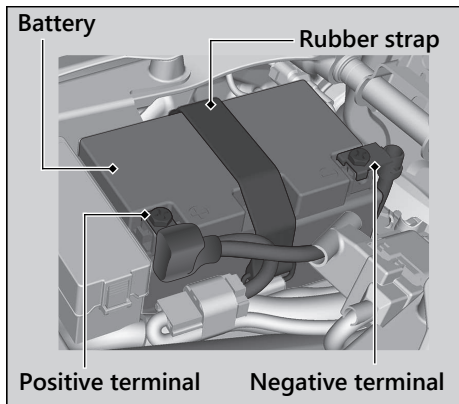

### Removal

Make sure the ignition switch is in the  (Off) position.

1. Remove the front seat. ➔ P. 129

2. Unhook the rubber strap from left side.
3. Disconnect the negative  $\ominus$  terminal from the battery.
4. Disconnect the positive  $\oplus$  terminal from the battery.
5. Remove the battery, taking care not to drop the terminal nuts.

### Installation

Install the parts in the reverse order of removal. Always connect the positive  $\oplus$  terminal first. Make sure bolts and nuts are tight.

Make sure the clock information is correct after the battery is reconnected. ➔ P. 67  
For proper handling of the battery, see "Maintenance Fundamentals." ➔ P. 117  
"Battery Goes Dead." ➔ P. 162

## Clip

### Removal



1. Press down on the centre pin to release the lock.
2. Pull the clip out of the hole.

### Installation

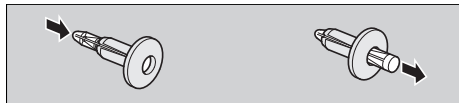

1. Push the bottom of the centre pin.
2. Insert the clip into the hole.
3. Press down on the centre pin to lock the clip.

## Front Seat

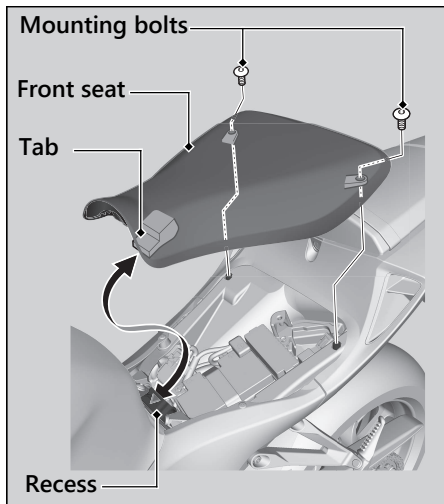

### Removal

1. Pull the rear corners of the front seat up, then remove the mounting bolts.
2. Pull the front seat back and up.

### Installation

1. Insert the tab into the recess.
2. Install and tighten the mounting bolts securely.  
Make sure that the seat is locked securely in position by pulling it up lightly.

## Right Middle Cowl

### Removal

1. Remove the bolts A and bolt B.
2. Remove the clips A and clip B.  P. 128

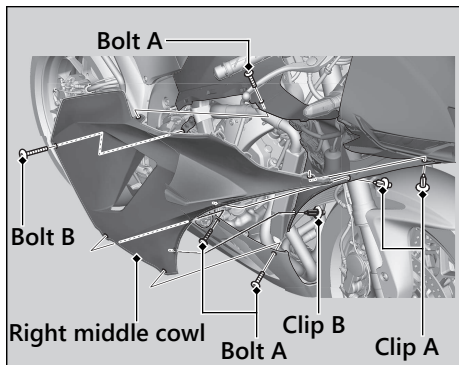

3. Remove the prongs and tab from the frame cover.
4. Remove the tab from the winglet.

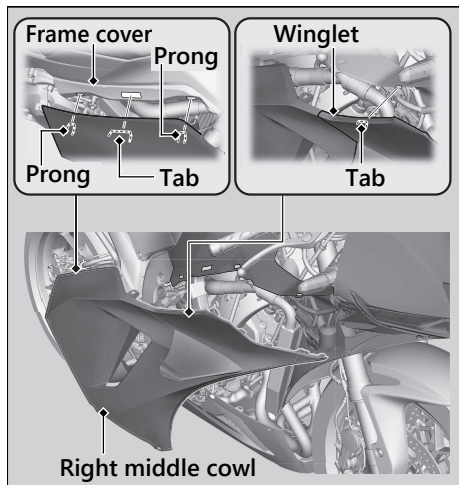

5. Remove the hook and tabs from the intake lower cover. Then remove the right middle cowl.

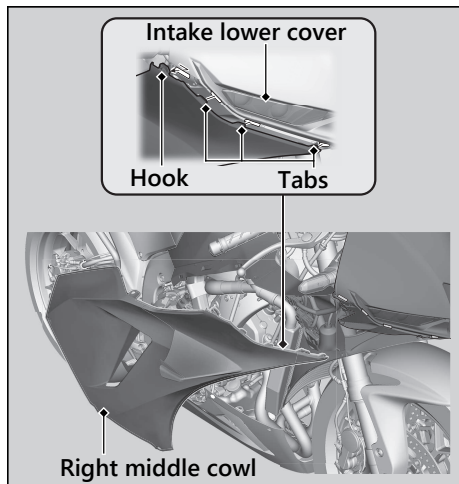

## Installation

1. Install the right middle cowl in the reverse order of removal.

## Rear Seat

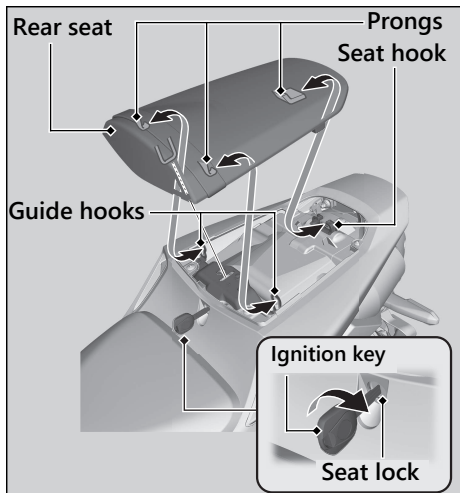

### Removal

1. Insert the ignition key into the seat lock.
2. Turn it clockwise, then pull the rear seat forward and up.

### Installation

1. Insert the prongs into the seat hook and guide hooks.
2. Push down on the front of the rear seat. Make sure that the seat is locked securely in position by pulling it up lightly. The seat locks automatically when closed. Take care not to lock your key in the compartment under the rear seat.



## Checking the Engine Oil

1. If the engine is cold, idle the engine for 3 to 5 minutes.
2. Turn the ignition switch to the **○** (Off) position and wait for 2 to 3 minutes.
3. Place your vehicle in an upright position on a firm, level surface.
4. Check that the oil level is between the upper level and lower level marks on the oil level inspection window.

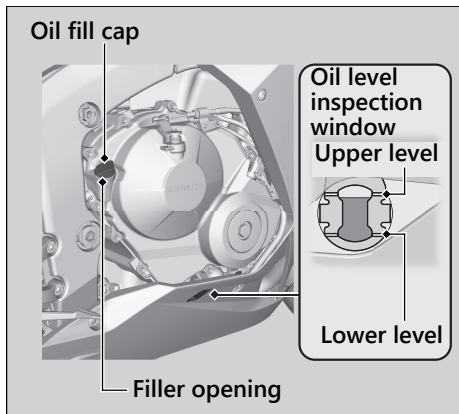

## Adding Engine Oil

---

If the engine oil is below or near the lower level mark, add the recommended engine oil.

► P. 119, ► P. 182

1. Remove the oil fill cap. Add the recommended oil until it reaches the upper level mark.
  - Place your vehicle in an upright position on a firm, level surface when checking the oil level.
  - Do not overfill above the upper level mark.
  - Make sure no foreign objects enter the oil filler opening.
  - Wipe up any spills immediately.

2. Securely reinstall the oil fill cap.

### NOTICE

Overfilling with oil or operating with insufficient oil can cause damage to your engine. Do not mix different brands and grades of oil. They may affect lubrication and clutch operation.

For the recommended oil and oil selection guidelines, see “Maintenance Fundamentals.”

► P. 119

## Checking the Coolant

Check the coolant level in the reserve tank while the engine is cold.

1. Place your vehicle on a firm, level surface.
2. Hold your vehicle in an upright position.
3. Check that the coolant level is between the UPPER level and LOWER level marks on the reserve tank.

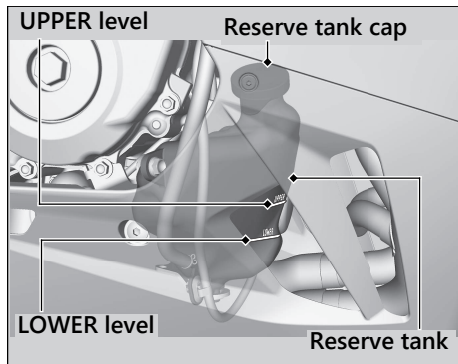

If the coolant level is dropping noticeably or the reserve tank is empty, you likely have a serious leak. Have your vehicle inspected by your dealer.

## Adding Coolant

If the coolant level is below the LOWER level mark, add the recommended coolant (► P. 122) until the level reaches the UPPER level mark.

Add fluid only from the reserve tank cap and do not remove the radiator cap.

1. Remove the right middle cowl. ► P. 130
2. Remove the reserve tank cap and add fluid while monitoring the coolant level.
  - Do not overfill above the UPPER level mark.
  - Make sure no foreign objects enter the reserve tank opening.
3. Securely reinstall the reserve tank cap.
4. Install the right middle cowl. ► P. 130

### **WARNING**

Removing the radiator cap while the engine is hot can cause the coolant to spray out, potentially scalding you.

Always let the engine and radiator cool down before removing the radiator cap.

## Checking Brake Fluid

1. Place your vehicle in an upright position on a firm, level surface.
2. Check that the brake fluid reservoir is horizontal and that the fluid level is between the LOWER level and UPPER level marks.

If the brake fluid level in either reservoir is below the LOWER level mark or the brake lever and pedal freeplay becomes excessive, inspect the brake pads for wear. If the brake pads are not worn, you most likely have a leak. Have your vehicle inspected by your dealer.

Front

Front brake fluid reservoir

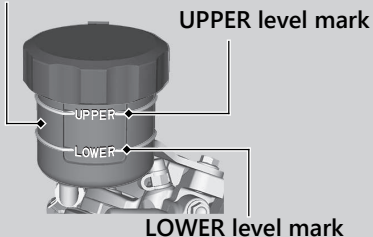

Rear

Rear brake fluid reservoir

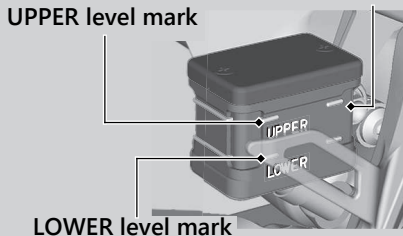

## Inspecting the Brake Pads

Check the condition of the brake pad wear indicators.

**Front** The pads need to be replaced if a brake pad is worn to the bottom of the indicator.

**Rear** The pads need to be replaced if a brake pad is worn to the indicator.

1. **Front** Inspect the brake pads from in front of the brake caliper.  
► Always inspect both left and right brake calipers.
2. **Rear** Inspect the brake pads from the rear right of the vehicle.

If necessary, have the pads replaced by your dealer.

Always replace both left and right brake pads at the same time.

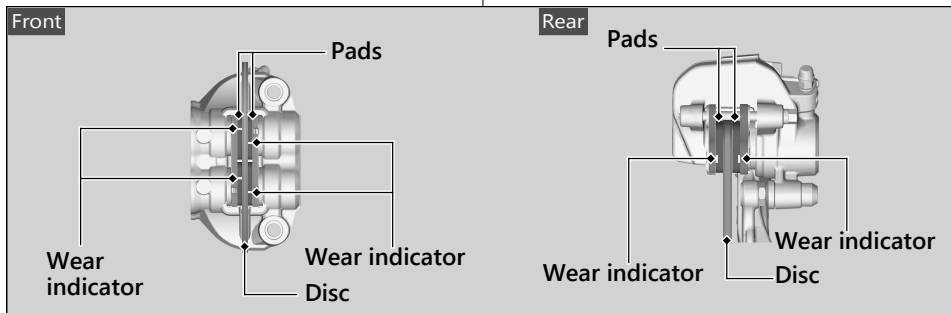

## Adjusting the Brakelight Switch

Check the operation of the brakelight switch. Hold the brakelight switch and turn the adjusting nut in the direction A if the switch operates too late, or turn the nut in the direction B if the switch operates too soon.

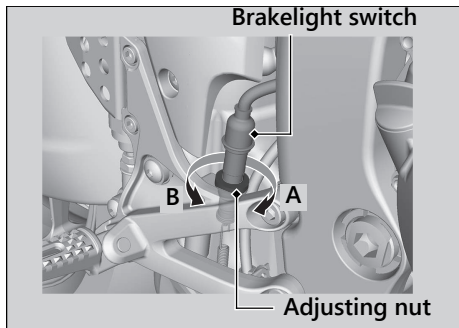

## Checking the Side Stand

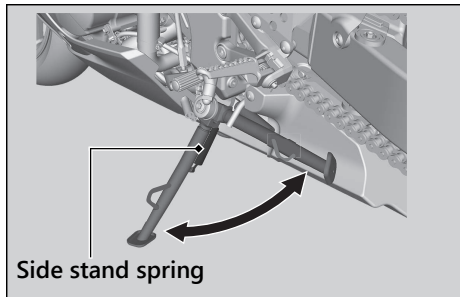

1. Check that the side stand operates smoothly. If the side stand is stiff or squeaky, clean the pivot area and lubricate the pivot bolt with clean grease.
2. Check the spring for damage or loss of tension.
3. Sit on the vehicle, shift the transmission to Neutral, and raise the side stand.

4. Start the engine, pull the clutch lever in, and shift the transmission into gear.
5. Lower the side stand all the way. The engine should stop as you lower the side stand. If the engine doesn't stop, have your vehicle inspected by your dealer.



## Inspecting the Drive Chain Slack

Check the drive chain slack at several points along the chain. If the slack is not constant at all points, some links may be kinked and binding.

Have the chain inspected by your dealer.

1. Shift the transmission to Neutral. Stop the engine.
2. Place your vehicle on its side stand on a firm, level surface.
3. Move the lower part of the drive chain up and down to check chain slack, midway between the sprockets.

### Drive chain slack:

30 - 40 mm (1.2 - 1.6 in)

- ▶ Do not ride your vehicle if the slack exceeds 50 mm (2.0 in).

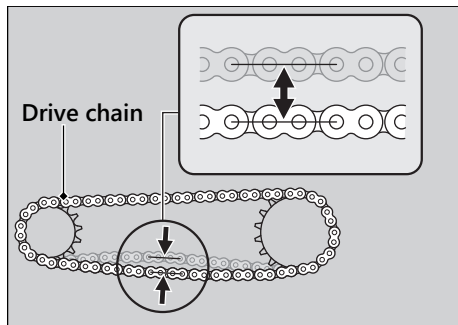

4. Roll the vehicle forward and check that the chain moves smoothly.
5. Inspect the sprockets. ➤ P. 120
6. Clean and lubricate the drive chain. ➤ P. 121

## Checking the Drive Chain Slider

Check the condition of the drive chain slider.

The drive chain slider will need to be replaced if the chain slider is worn to the wear limit line.

If necessary, have the drive chain slider replaced by your dealer.

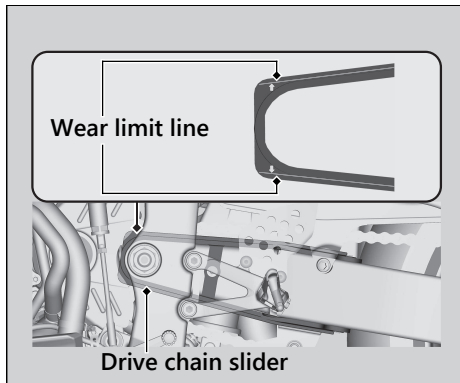

## Checking the Clutch

### Checking the Clutch Lever Freeplay

Check the clutch lever freeplay.

#### Freeplay at the clutch lever:

10 - 20 mm (0.4 - 0.8 in)

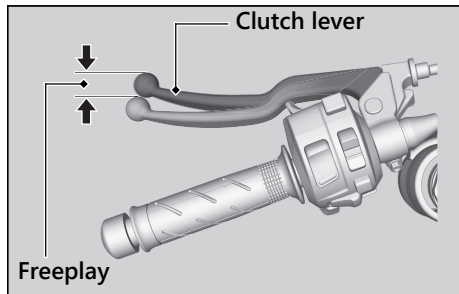

Check the clutch cable for kinks or signs of wear. If necessary, have it replaced by your dealer.

Lubricate the clutch cable with a commercially available cable lubricant to prevent premature wear and corrosion.

#### NOTICE

Improper freeplay adjustment can cause premature clutch wear.

## Adjusting the Clutch Lever Freeplay

### Upper Adjustment

Attempt adjustment with the upper clutch cable adjuster first.

Turn the clutch cable adjuster until the freeplay is 10 - 20 mm (0.4 - 0.8 in).

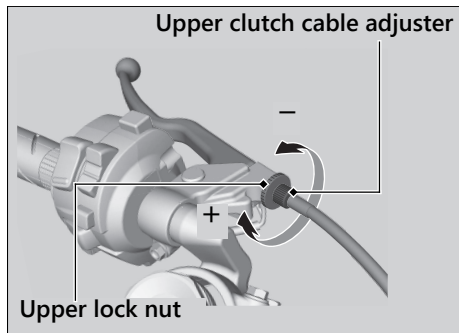

## Lower Adjustment

If the upper clutch cable adjuster is threaded out near its limit, or the correct freeplay cannot be obtained, attempt adjustment with the lower clutch cable adjusting nut.

1. Turn the upper clutch cable adjuster all the way in (to provide maximum freeplay).
2. Loosen the lower lock nut.
3. Turn the adjusting nut until the clutch lever freeplay is 10 - 20 mm (0.4 - 0.8 in).
4. Tighten the lower lock nut and check the clutch lever freeplay.
5. Start the engine, pull the clutch lever in, and shift into gear. Make sure the engine does not stall and the vehicle does not creep. Gradually release the clutch lever and open the throttle. Your vehicle should move smoothly and accelerate gradually.

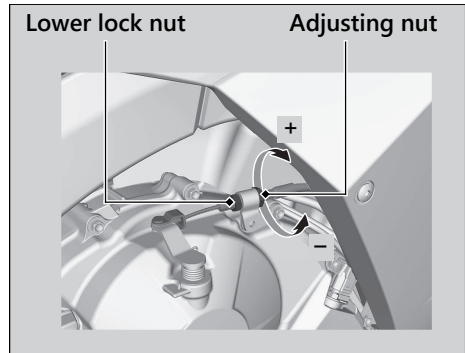

If proper adjustment cannot be obtained or the clutch does not work correctly, see your dealer.

## Checking the Throttle

---

With the engine off, check that the throttle rotates smoothly from fully closed to fully open. If the throttle does not move smoothly or close automatically, have the vehicle inspected by your dealer.

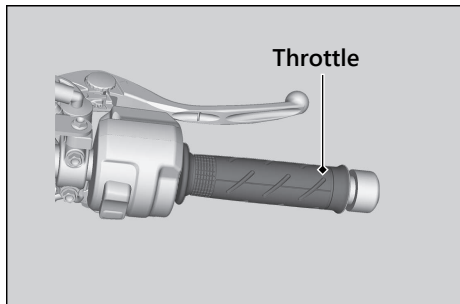

### Adjusting the Brake Lever

You can adjust the distance between the brake lever and handle grip.

#### Adjustment method

Turn the adjuster until the numbers align with the index mark while pushing the lever forward in the desired position.

After adjustment, check that the lever operates correctly before riding.

#### NOTICE

Do not turn the adjuster beyond its natural limit.

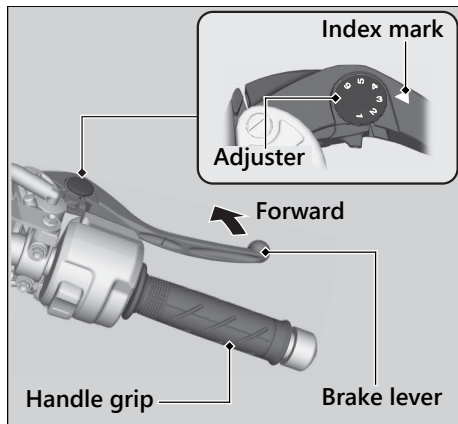

## Adjusting the Front Suspension

### Spring Preload

You can adjust the spring preload by the adjuster to suit the load or the road surface. The spring preload adjuster has 15 turns. Turn clockwise to increase spring preload (hard), or turn counterclockwise to decrease spring preload (soft). The standard position is the 4 1/2 turns from the full soft position.

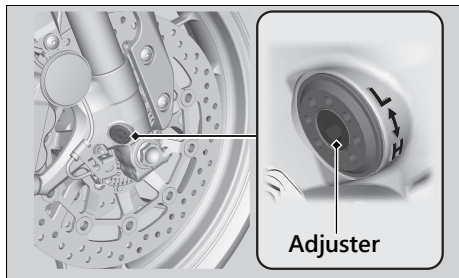

#### NOTICE

Do not turn the adjuster beyond its limits. Adjust both left and right forks to the same spring preload.



## Rebound Damping

You can adjust the rebound damping by the TEN adjuster to suit the load or the road surface.

The TEN adjuster has 5 1/2 turns.

Turn clockwise to increase rebound damping (hard), or turn counterclockwise to decrease rebound damping (soft). The standard position is 4 3/4 turns from the full hard position.

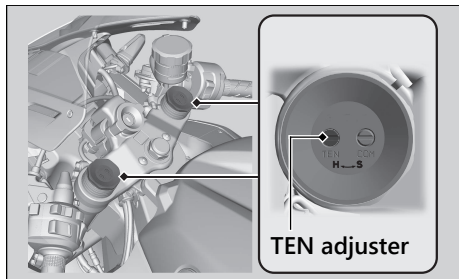

### NOTICE

Do not turn the adjuster beyond its limits. Adjust both left and right forks to the same rebound damping.

## Compression Damping

You can adjust the compression damping by the COM adjuster to suit the load or the road surface.

The COM adjuster has 7 turns.

Turn clockwise to increase compression damping (hard), or turn counterclockwise to decrease compression damping (soft). The standard position is 6 turns from the full hard position.

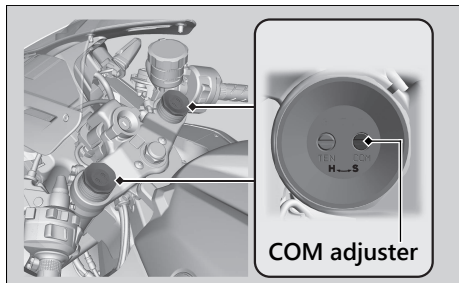

### NOTICE

Do not turn the adjuster beyond its limits. Adjust both left and right forks to the same compression damping.

## Adjusting the Rear Suspension

Adjusting the suspension requires a pin spanner. We recommend that you have your vehicle serviced by your dealer.

### Spring Preload

You can adjust the spring preload by the adjuster to suit the load or the road surface. Turn the adjuster using the pin spanner. The preload adjuster has 10 positions. Position 1 is for a decrease spring preload (soft), or turn the position 3 to 10 increase spring preload (hard). The standard position is 2.

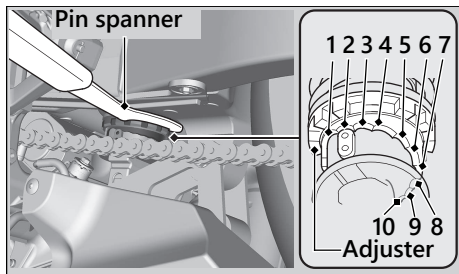

#### NOTICE

Do not turn the adjuster beyond its limits. Attempting to adjust directly from 1 to 10 or 10 to 1 may damage the shock absorber.

#### NOTICE

The rear shock absorber damper unit contains high pressure nitrogen gas. Do not attempt to disassemble, service, or improperly dispose of the damper. See your dealer.

## Rebound Damping

You can adjust the rebound damping by the adjuster to suit the load or the road surface. The rebound damping has 3 turns.

Turn clockwise to increase rebound damping (hard), or turn counterclockwise to decrease rebound damping (soft).

The standard position is 2 3/4 turns from the maximum setting so that the punch mark on the adjuster aligns with the reference punch mark.

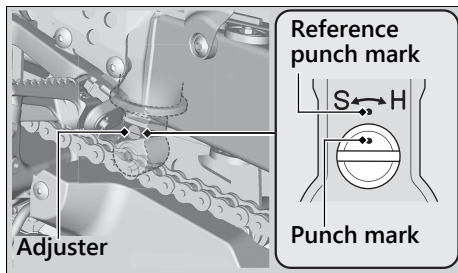

### NOTICE

Do not turn the adjuster beyond its limits.

### NOTICE

The rear shock absorber damper unit contains high pressure nitrogen gas. Do not attempt to disassemble, service, or improperly dispose of the damper. See your dealer.

## Compression Damping

You can adjust the compression damping by the adjuster to suit the load or the road surface.

The compression damping adjuster has 32 clicks.

Turn clockwise to increase compression damping (hard), or turn counterclockwise to decrease compression damping (soft).

The standard position is 18 clicks from the maximum setting so that the punch mark on the adjuster aligns with the reference punch mark.

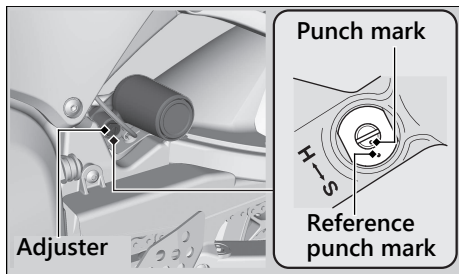

### NOTICE

Do not turn the adjuster beyond its limits.

### NOTICE

The rear shock absorber damper unit contains high pressure nitrogen gas. Do not attempt to disassemble, service, or improperly dispose of the damper. See your dealer.

# Troubleshooting

**Engine Will Not Start (HISS indicator stays on)**..... P. 155

**Overheating (High coolant temperature indicator is on)**..... P. 156

**Warning Indicators On or Flashing**..... P. 157

Low Oil Pressure Indicator ..... P. 157

PGM-FI (Programmed Fuel Injection)

Malfunction Indicator Lamp (MIL)..... P. 158

ABS (Anti-lock Brake System) Indicator ..... P. 159

HESD (Honda Electronic Steering Damper)

Indicator ..... P. 159

Torque Control Indicator..... P. 160

**Tyre Puncture** ..... P. 161

**Electrical Trouble**..... P. 162

Battery Goes Dead..... P. 162



Burned-out Light Bulb ..... P. 162

Blown Fuse..... P. 164

### Starter Motor Operates But Engine Does Not Start

---

Check the following items:

- Check the correct engine starting sequence. ➔ P. 99
- Check that there is petrol in the fuel tank.
- Check if the PGM-FI malfunction indicator lamp (MIL) is on.
  - ▶ If the indicator lamp is on, contact your dealer as soon as possible.
- Check if the HISS indicator stays on.
  - ▶ Turn the ignition switch to the  (Off) position and remove the key. Reinsert the key and turn the ignition switch to the  (On) position. If the indicator still stays on, check the following:  
Check if there is no another HISS key (including spare key) close to the ignition switch.

Check if there are no any metallic seals or stickers on the key.

If the HISS indicator still stays on, have your vehicle inspected by your dealer.

### Starter Motor Does Not Operate

---

Check the following items:

- Check the correct engine starting sequence. ➔ P. 99
- Make sure engine stop switch is in the  (Run) position. ➔ P. 90
- Check for a blown fuse. ➔ P. 164
- Check for a loose battery connection (➔ P. 127) or battery terminal corrosion (➔ P. 117).
- Check the condition of the battery.  
➔ P. 162

If the problem continues, have your vehicle inspected by your dealer.

## Overheating (High coolant temperature indicator is on)

The engine is overheating when the following occurs:

- High coolant temperature indicator comes on.
- Acceleration becomes sluggish.  
If this occurs, pull safely to the side of the road and perform the following procedure.

Extended fast idling may cause the high coolant temperature indicator to come on.

### NOTICE

Continuing to ride with an overheated engine can cause serious damage to the engine.

1. Stop the engine using the ignition switch, and then turn the ignition switch to the **I** (On) position.

2. Check that the radiator fan is operating, and then turn the ignition switch to the **O** (Off) position.

### If the fan is not operating:

Suspect a fault. Do not start the engine. Transport your vehicle to your dealer.

### If the fan is operating:

Allow the engine to cool with the ignition switch in the **O** (Off) position.

3. After the engine has cooled, inspect the radiator hose and check if there is a leak.  
➔ P. 135

### If there is a leak:

Do not start the engine. Transport your vehicle to your dealer.

4. Check the coolant level in the reserve tank. ➔ P. 135  
▶ Add coolant as necessary.
5. If 1-4 check normal, you may continue riding, but closely monitor the high coolant temperature indicator.



## Low Oil Pressure Indicator

---

If the low oil pressure indicator comes on, pull safely to the side of the road and stop the engine.

### NOTICE

Continuing to ride with low oil pressure can cause serious damage to the engine.

1. Check the engine oil level, and add oil as necessary. 📄 P. 133, 📄 P. 134
2. Start the engine.
  - ▶ Only continue riding if the low oil pressure indicator goes off.

Rapid acceleration may momentarily cause the low oil pressure indicator to come on, especially if the oil is at or near the low level. If the low oil pressure indicator stays on when the oil level is at the proper level, stop the engine and contact your dealer.

If the engine oil level goes down rapidly, your vehicle may have a leak or another serious problem. Have your vehicle inspected by your dealer.

## PGM-FI (Programmed Fuel Injection) Malfunction Indicator Lamp (MIL)

---

### GS type

If the indicator comes on while riding, you may have a serious problem with the PGM-FI system. Reduce speed and have your vehicle inspected by your dealer as soon as possible.

### ED, II ED type

#### Reasons for the indicator lamp to come on or blink

- Comes on if there is a problem with the engine emissions control system.
- Blinks when engine misfiring is detected.

#### What to do when the indicator lamp comes on

Avoid high speeds and immediately get your vehicle inspected at a dealer.

#### NOTICE

If you drive with the malfunction indicator lamp on, the emissions control system and the engine could be damaged.

#### What to do when the indicator lamp blinks

Park the vehicle in a safe place with no flammable items and wait at least 10 minutes with the engine stopped until it cools.

#### NOTICE

If the malfunction indicator lamp blinks again when restarting the engine, drive to the nearest dealer at 50 km/h (31 mph) or less. Have your vehicle inspected.

## ABS (Anti-lock Brake System) Indicator

---

If the indicator operates in one of the following ways, you may have a serious problem with the ABS. Reduce your speed and have your vehicle inspected by your dealer as soon as possible.

- Indicator comes on or starts flashing while riding.
- Indicator does not come on when the ignition switch is in the **I** (On) position.
- Indicator does not go off at speeds above 10 km/h (6 mph).

If the ABS indicator stays on, your brakes will continue to work as a conventional system, but without the anti-locking function.

The ABS indicator may flash if you turn the rear wheel while the rear wheel is lifted off the ground. In this case, turn the ignition switch to the **O** (Off) position, and then to the **I** (On) position again. The ABS indicator will go off after your speed reaches 30 km/h (19 mph).

## HESD (Honda Electronic Steering Damper) Indicator

---

If the indicator comes on while riding, you may have a serious problem with the HESD. Reduce speed and have your vehicle inspected by your dealer as soon as possible.

## Torque Control Indicator

---

If the indicator operates in one of the following ways, you may have a serious problem with the Torque Control. Reduce your speed and have your vehicle inspected by your dealer as soon as possible.

- Indicator comes and stays on (solid) while riding.
- Indicator does not come on when the ignition switch is turned to the **I** (On) position.
- Indicator does not go off at speeds above 5 km/h (3 mph).

Even when the Torque Control indicator is on, your vehicle will have normal riding ability without Torque Control function.

- When the indicator comes on while the Torque Control is in operation, you will have to completely close the throttle to regain normal riding ability.

The Torque Control indicator may come on if you rotate the rear wheel while your vehicle is lifted off the ground. In this case, turn the ignition switch to the **O** (Off) position, and then to the **I** (On) position again. The Torque Control indicator will go off after your speed reaches 5 km/h (3 mph).

## Tyre Puncture

Repairing a puncture or removing a wheel requires special tools and technical expertise. We recommend you have this type of service performed by your dealer.

After an emergency repair, always have the tyre inspected/replaced by your dealer.

### Emergency Repair Using a Tyre Repair Kit

---

If your tyre has a minor puncture, you can make an emergency repair using a tubeless tyre repair kit.

Follow the instructions provided with the emergency tyre repair kit.

Riding your vehicle with a temporary tyre repair is very risky. Do not exceed 50 km/h (30 mph). Have the tyre replaced by your dealer as soon as possible.

### **WARNING**

Riding your vehicle with a temporary tyre repair can be risky. If the temporary repair fails, you can crash and be seriously injured or killed.

If you must ride with a temporary tyre repair, ride slowly and carefully and do not exceed 50 km/h (30 mph) until the tyre is replaced.

### Battery Goes Dead

---

Charge the battery using a motorcycle battery charger.

Remove the battery from the vehicle before charging.

Do not use an automobile-type battery charger, as these can overheat a motorcycle battery and cause permanent damage. If the battery does not recover after recharging, contact your dealer.



#### NOTICE

Jump starting using an automobile battery can damage your vehicle's electrical system and is not recommended.

### Burned-out Light Bulb

---

Follow the procedure below to replace a burned-out light bulb.

Turn the ignition switch to the  (Off) or  (Lock) position.

Allow the bulb to cool before replacing it.

Check the replacement bulb for correct operation before riding.

Do not use bulbs other than those specified.

For the light bulb wattage, see "Specifications."  P. 183

The headlights, front turn signals/position lights, brakelight, taillight and rear turn signals use several LEDs.

If there is an LED which is not turned on, see your dealer for servicing.

## License Plate Light Bulb

1. Remove the screws, license light cover and license light cover packing.
2. Pull out the bulb without turning.

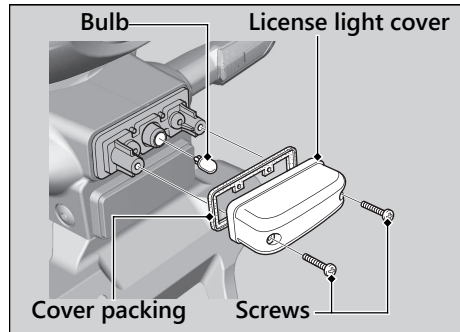

3. Install a new bulb and reinstall the parts in the reverse order of removal.

## Blown Fuse

Before handling fuses, see “Inspecting and Replacing Fuses.” ► P. 119

### Fuse Box Fuses

1. Remove the front seat. ► P. 129
2. Remove the fuse box cover.
3. Pull the fuses out one by one with the fuse puller in the tool kit and check for a blown fuse. Always replace a blown fuse with a spare fuse of the same rating.
4. Reinstall the fuse box cover.
5. Reinstall the front seat.

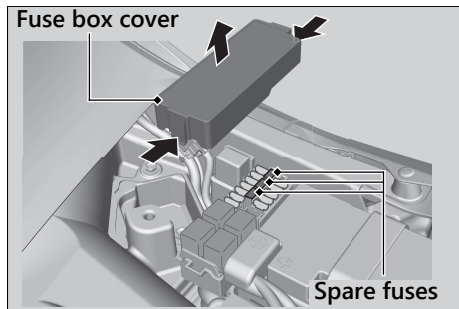



## I Main Fuse

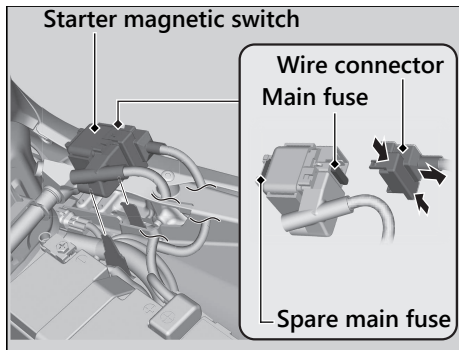

1. Remove the front seat. ► P. 129
2. Disconnect the wire connector of the starter magnetic switch.
3. Pull the main fuse out and check for a blown fuse. Always replace a blown fuse with a spare of the same rating.
  - Spare main fuse is provided in the starter magnetic switch.
4. Reinstall parts in the reverse order of removal.

### NOTICE

If a fuse fails repeatedly, you likely have an electrical problem. Have your vehicle inspected by your dealer.

# Information

Service Diagnostic Recorders .....	P. 167
Keys.....	P. 167
Instruments, Controls, & Other Features...	P. 168
Caring for Your Vehicle.....	P. 171
Storing Your Vehicle.....	P. 175
Transporting Your Vehicle .....	P. 176
You & the Environment .....	P. 177
Serial Numbers .....	P. 178
Fuels Containing Alcohol .....	P. 179
Catalytic Converter .....	P. 180

## Service Diagnostic Recorders

### ED, II ED type

Your vehicle is equipped with service-related devices that record information about powertrain performance and riding conditions. The data can be used to help technicians diagnose, repair and maintain the vehicle. This data may not be accessed by anyone else except as legally required or with the permission of the vehicle owner.

However this data may be accessed by Honda, its authorised dealers and authorised repairers, employees, representatives and contractors only for the purpose of the technical diagnosis, research and development of the vehicle.

## Keys

### Ignition Key

The ignition key contains a special coded chip that is recognized by the immobilizer system (HISS) in order to start the engine. Handle the key carefully to prevent damaging the HISS components.

- Do not bend keys or subject them to undue stress.
- Avoid prolonged exposure to sunlight or high temperatures.
- Do not grind, drill or in any way alter their shape.
- Do not expose to strong magnetic objects.

If you lose all ignition keys and the key number plate, the PGM-FI unit/ignition control module must be replaced by your dealer. To avoid this, keep a duplicate key.

If you lose a key, make another duplicate key immediately.

## Instruments, Controls, & Other Features

To make a duplicate key and register it with your HISS system, take the spare key, the key number plate, and the vehicle to your dealer.

- ▶ Store the key number plate in a safe location.

A metal key holder may cause damage to the area surrounding the ignition switch.

## Instruments, Controls, & Other Features

### Ignition Switch

Leaving the ignition switch in the **I** (On) position with the engine stopped will drain the battery.

Do not turn the key while riding.

### Engine Stop Switch

Do not use the engine stop switch except in an emergency. Doing so when riding will cause the engine to suddenly turn off, making riding unsafe.

If you stop the engine using the engine stop switch, turn the ignition switch to the **O** (Off) position. Failing to do so will drain the battery.

## Odometer



The display remains at 999,999 when the odometer exceeds 999,999.

## Tripmeter

Each tripmeter resets to 0.0 when the trip mileage exceeds 9,999.9.

## HISS

The Honda Ignition Security System (HISS) immobilizes the engine's ignition system if an improperly-coded key is used to try and start the engine. When the ignition switch is turned to the  (Off) position, the HISS immobilizer system is always alert, even if the HISS indicator is not flashing.

If the ignition switch is turned to the  (On) position with the engine stop switch in the  (Run) position, the HISS indicator turns on and goes off after a few seconds to indicate it is OK to start the engine. **HISS Indicator Does Not Turn off**  P. 155

The HISS indicator starts flashing every 2 seconds for 24 hours after the ignition switch is turned to the  (Off) position. You can turn this feature on or off.  P. 51

## EU Directive

This immobilizer system complies with the RE (Radio Equipment) Directive (2014/53/EU).



The declaration of conformity to RE Directive is provided to the owner at the time of purchase. The declaration of conformity should be kept at a safe place. When the declaration of conformity is lost or is not provided, contact your dealer.

### Document Bag

The owner's manual, registration, and insurance information can be stored in the plastic document bag located under the rear seat.

### Ignition Cut-off System

IMU (Inertia Measurement Unit) sensor automatically stops the engine and fuel pump if the vehicle falls over. To reset the IMU, you must turn the ignition switch to the **O** (Off) position and back to the **I** (On) position before the engine can be restarted.

If a failure of the IMU is detected, the engine and fuel pump will not stop automatically when the vehicle falls over.

### HESD

The Honda Electronic Steering Damper (HESD) automatically controls the steering damper characteristics in accordance with vehicle speed and acceleration.

**HESD Indicator Comes On**  P. 159

### Assist-slipper Clutch System

The assist-slipper clutch system helps to prevent the rear tyre from locking up when the deceleration of your vehicle produces a strong engine braking effect. It also makes the clutch lever operation feel lighter.

Use only MA classification engine oil for your vehicle. Using engine oil other than MA classification oil could result in damage to the assist-slipper clutch system.

### Throttle by Wire System

This model is equipped with a Throttle by Wire System.

Do not put magnetized items or items susceptible to magnetic interference near the right handlebar switches.

### Automatic Brightness Control

The backlight brightness of the meter will be controlled automatically when "AUTO" is selected on the brightness setting.

Ambient brightness is detected by the photosensor.

Do not damage or cover the photosensor. Otherwise, the automatic brightness control may not work properly.

Photosensor

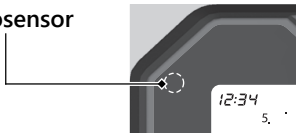

## Caring for Your Vehicle

Frequent cleaning and polishing is important to ensure the life of your Honda. A clean vehicle makes it easier to spot potential problems. In particular, seawater and salts used to prevent ice on roads promote the formation of corrosion. Also, mud and dust may accelerate front fork wear and cause oil leaks. Always wash your vehicle thoroughly after riding on coastal, treated roads, muddy or dusty roads.

### Washing

Allow the engine, muffler, brakes, and other high-temperature parts to cool before washing.

1. Rinse your vehicle thoroughly using a low pressure garden hose to remove loose dirt.
2. If necessary, use a sponge or a soft towel with mild cleaner to remove road grime.
  - ▶ Clean the windscreen, headlight lens, panels, and other plastic components with extra care to avoid scratching them.

## Caring for Your Vehicle

Avoid directing water into the air cleaner, muffler, and electrical parts.

3. Thoroughly rinse your vehicle with plenty of clean water and dry with a soft, clean cloth.
4. After the vehicle dries, lubricate any moving parts.
  - ▶ Make sure that no lubricant spills onto the brakes or tyres. Brake discs, pads, drum or shoes contaminated with oil will suffer greatly reduced braking effectiveness and can lead to a crash.
5. Lubricate the drive chain immediately after washing and drying the vehicle.
6. Apply a coat of wax to prevent corrosion.
  - ▶ Avoid products that contain harsh detergents or chemical solvents. These can damage the metal, paint, and plastic on your vehicle.  
Keep the wax clear of the tyres and brakes.
  - ▶ If your vehicle has any mat painted parts, do not apply a coat of wax to the mat painted surface.

## Washing Precautions

Follow these guidelines when washing:

- Do not use high-pressure washers:
  - ▶ High-pressure water cleaners can damage moving parts and electrical parts, rendering them inoperable.
  - ▶ Water in the air intake can be drawn into the throttle body and/or enter the air cleaner.
- Do not direct water at the muffler:
  - ▶ Water in the muffler can prevent starting and causes rust in the muffler.
- Dry the brakes:
  - ▶ Water adversely affects braking effectiveness. After washing, apply the brakes intermittently at low speed to help dry them.
- Do not direct water under the seat:
  - ▶ Water in the under seat compartment can damage your documents and other belongings.



- Do not direct water at the air cleaner:
  - ▶ Water in the air cleaner can prevent the engine from starting.
- Do not direct water near the headlight:
  - ▶ The headlight's inside lens may fog temporarily after washing or while riding in the rain. This does not impact the headlight function.  
However, if you see a large amount of water or ice accumulated inside the lens(es), have your vehicle inspected by your dealer.
- Do not use wax or polishing compounds on mat painted surfaces:
  - ▶ Use a soft cloth or sponge, plenty of water, and a mild detergent to clean mat painted surfaces. Dry with a soft clean cloth.

### Aluminium Components

Aluminium will corrode from contact with dirt, mud, or road salt. Clean aluminium parts regularly and follow these guidelines to avoid scratches:

- Do not use stiff brushes, steel wool, or cleaners containing abrasives.
- Avoid riding over or scraping against curbs.

### Panels

Follow these guidelines to prevent scratches and blemishes:

- Wash gently using a soft sponge and plenty of water.
- To remove stubborn stains, use diluted detergent and rinse thoroughly with plenty of water.
- Avoid getting petrol, brake fluid, or detergents on the instruments, panels, or headlight.

## Caring for Your Vehicle

### Windscreen

Using plenty of water, clean the windscreen with a soft cloth or sponge. (Avoid using detergents or any kind of chemical cleaner on the windscreen.) Dry with a soft, clean cloth.

#### NOTICE

To avoid possible scratching or other damage, use only water and a soft cloth or sponge to clean the windscreen.

For a dirtier windscreen, use a diluted neutral detergent with a sponge and plenty of water. Make sure to wash off all the detergent. (Detergent residue may cause windscreen cracks.)

Replace the windscreen if scratches cannot be removed and they obstruct clear vision.

Take care to keep battery electrolyte, brake fluid, or other chemical solvents off the windscreen and screen garnish. They will damage the plastic.

### Exhaust Pipe and Muffler

The exhaust pipe and muffler are stainless steel but may become stained by mud or dust.

To remove mud or dust, use a wet sponge and a liquid kitchen abrasive, then rinse well with clean water. Dry with chamois or a soft towel.

If necessary, remove heat stains by using a commercially available fine texture compound. Then, rinse by the same manner as removing mud or dust.

#### NOTICE

Even though the exhaust is made of stainless steel, it can become stained. Remove all marks and blemishes as soon as they are noticed.

## Front fork

Mud and dust may accelerate wear on the front forks and cause oil leaks.

To avoid scratching, please handle the forks with the following care.

- Wash gently using a soft sponge and plenty of water.
- To remove stubborn stains, use diluted detergent and rinse thoroughly with plenty of water.

## Storing Your Vehicle

If you store your vehicle outdoors, you should consider using a full-body cover.

If you won't be riding for an extended period, follow these guidelines:

- Wash your vehicle and wax all painted surfaces (except mat painted surfaces). Coat chrome pieces with rust-inhibiting oil.
- Lubricate the drive chain. ➤ P. 120
- Place your vehicle on a maintenance stand and position a block so that both tyres are off the ground.
- After rain, remove the body cover and allow the vehicle to dry.

## Transporting Your Vehicle

- Remove the battery (➤ P. 127) to prevent discharge. Fully charge the battery and then place it in a shaded, well-ventilated area.
  - ▶ If you leave the battery in place, disconnect the negative ⊖ terminal to prevent discharge.

After removing your vehicle from storage, inspect all maintenance items required by the Maintenance Schedule.

## Transporting Your Vehicle

If your vehicle needs to be transported, it should be carried on a motorcycle trailer or a flatbed truck or trailer that has a loading ramp or lifting platform and motorcycle tie-down straps. Never try to tow your vehicle with a wheel or wheels on the ground.

### NOTICE

Towing your vehicle with a wheel or wheels on the ground can cause serious damage to the transmission.

## You & the Environment

Owning and riding a vehicle can be enjoyable, but you must do your part to protect the environment.

### Choose Sensible Cleaners

Use a biodegradable detergent when you wash your vehicle. Avoid aerosol spray cleaners that contain chlorofluorocarbons (CFCs) which damage the atmosphere's protective ozone layer.

### Recycle Wastes

Put oil and other toxic wastes in approved containers and take them to a recycling centre. Call your local or state office of public works or environmental services to find a recycling centre in your area and to get instructions on how to dispose of non-recyclable wastes. Do not place used engine oil in the trash or pour it down a drain or on the ground. Used oil, petrol, coolant, and cleaning solvents contain poisons that can hurt refuse workers and contaminate drinking water, lakes, rivers, and oceans.

## Serial Numbers

The frame and engine serial numbers uniquely identify your vehicle and are required in order to register your vehicle. They may also be required when ordering replacement parts. You should record these numbers and keep them in a safe place.

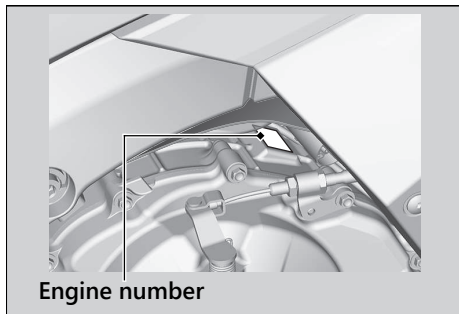
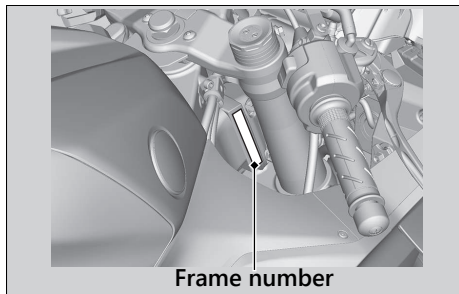

## Fuels Containing Alcohol

Some conventional fuels blended with alcohol are available in some locales to help reduce emissions to meet clean air standards. If you plan to use blended fuel, check that it is unleaded and meets the minimum octane rating requirement.

The following fuel blends can be used in your vehicle:

- Ethanol (ethyl alcohol) up to 10% by volume.
  - ▶ Petrol containing ethanol may be marketed under the name Gasohol.

The use of petrol containing more than 10% ethanol may:

- Damage the painting of the fuel tank.
- Damage the rubber tubes of the fuel line.
- Cause corrosion of the fuel tank.
- Cause poor drivability.

### NOTICE

Use of blended fuels containing higher than approved percentages can damage metal, rubber, plastic parts of your fuel system.

If you notice any undesirable operating symptoms or performance problems, try a different brand of petrol.

## Catalytic Converter

This vehicle is equipped with a three-way catalytic converter. The catalytic converter contains precious metals that serve as catalysts in high temperature chemical reactions that convert hydrocarbons (HC), carbon monoxide (CO), and oxides of nitrogen (NOx) in the exhaust gases into safe compounds.

A defective catalytic converter contributes to air pollution and can impair your engine's performance. A replacement unit must be an original Honda part or equivalent.

Follow these guidelines to protect your vehicle's catalytic converter:

- Always use unleaded petrol. Leaded petrol will damage the catalytic converter.
- Keep the engine in good running condition.
- Have your vehicle serviced if your engine is misfiring, backfiring, stalling, or otherwise not running properly, stop riding and turn off the engine.



# Specifications

## ■ Main Components

Overall length	2,030 mm (79.9 in)
Overall width	685 mm (27.0 in)
Overall height	1,140 mm (44.9 in)
Wheelbase	1,370 mm (53.9 in)
Minimum ground clearance	125 mm (4.9 in)
Caster angle	24° 6'
Trail	100 mm (3.9 in)
Curb weight	193 kg (425 lb)
Maximum weight capacity *1	180 kg (397 lb)
Maximum luggage weight *2	14 kg (31 lb)
Passenger capacity	Rider and 1 passenger
Minimum turning radius	3.20 m (10.5 ft)

\*1 : Including rider, passenger, all luggage, and accessories

\*2 : Includes the weight of the luggage and added accessories

Displacement	599 cm <sup>3</sup> (36.5 cu-in)
Bore x stroke	67.0 x 42.5 mm (2.64 x 1.67 in)
Compression ratio	12.2:1
Fuel	Unleaded petrol ED, II ED type 95 RON or higher GS type Recommended: 95 RON or higher
Fuel containing alcohol	ETHANOL up to 10 % by volume
Tank capacity	18 L (4.8 US gal, 4.0 Imp gal)
Battery	YTZ10S 12 V-8.6 Ah (10 HR) / 9.1 Ah (20 HR)
Gear ratio	1st 2.615
	2nd 2.000
	3rd 1.666
	4th 1.444
	5th 1.304
	6th 1.208
Reduction ratio (primary / final)	2.111 / 2.625

## Specifications

### ■ Service Data

Tyre size	Front	120/70ZR17M/C (58W)
	Rear	180/55ZR17M/C (73W)
Tyre type	Radial, tubeless	
Recommended tyre	Front	DUNLOP SPORTMAX Roadsport2 J
	Rear	DUNLOP SPORTMAX Roadsport2 J
Tyre category of use *1	Normal	Permitted
	Special	Not Permitted
	Snow *2	Not Permitted
	Moped	Not Permitted
Tyre air pressure	Front	250 kPa (2.50 kgf/cm <sup>2</sup> , 36 psi)
	Rear	290 kPa (2.90 kgf/cm <sup>2</sup> , 42 psi)
Minimum tread depth	Front	1.5 mm (0.06 in)
	Rear	2.0 mm (0.08 in)
Spark plug (standard)	SILMAR9C9 (NGK)	
Spark plug gap	0.8 - 0.9 mm (0.03 - 0.04 in)	
Idle speed	1,400 ± 100 rpm	

\*1 : Categorized by UNECE Regulation No. 75

\*2 : Snow is not limited as snow, but includes DP (Dual Purpose), M+S, MS, M&S (mud and snow)

Recommended engine oil	Honda 4-stroke motorcycle oil API Service Classification SJ or higher, excluding oils marked as "Energy Conserving" or "Resource Conserving," SAE 10W-30, JASO T 903 standard MA	
Engine oil capacity	After draining	2.6 L (2.7 US qt, 2.3 Imp qt)
	After draining & engine oil filter change	2.7 L (2.9 US qt, 2.4 Imp qt)
	After disassembly	3.4 L (3.6 US qt, 3.0 Imp qt)
Recommended brake fluid	Honda DOT 4 Brake Fluid	
Cooling system capacity	2.76 L (2.92 US qt, 2.43 Imp qt)	
Recommended coolant	Pro Honda HP Coolant	
Recommended drive chain lubricant	Drive chain lubricant designed specifically for O-ring chains If not available, use SAE 80 or 90 gear oil.	
Drive chain slack	30 - 40 mm (1.2 - 1.6 in)	
Standard drive chain	DID525HV3	
	No. of links	112

Standard	Drive sprocket	16T
sprocket size	Driven sprocket	42T

### ■ Bulbs

Headlight	LED
Brakelight/Taillight	LED
Front turn signal/Position light	LED
Rear turn signal	LED
License plate light	12 V-5 W

### ■ Fuses

Main fuse	30 A
Other fuse	30 A, 20 A, 10 A

Online Owner's Manual

<https://www.hondamotopub.com/>



32MKZ700  
00X32-MKZ-7000

XXX.XXXX.XX.R  
PRINTED IN XXXXX